

# Autopilot reach truck 1.6 - 2.5 ton



## **BT reflex** *AUTOPILOT*

RRE160

RRE200

RRE250



# Autopilot reach truck

Truck specifications					RRE160	RRE200	RRE250
Identification	1.1	Manufacturer			BT	BT	BT
	1.2	Model			RRE160	RRE200	RRE250
	1.3	Drive			Electric	Electric	Electric
	1.4	Operator type			Seated	Seated	Seated
	1.5	Load capacity/rated load	Q	kg	1600	2000	2500
	1.6	Load centre	c	mm	600	600	600
	1.8	Load distance, centre of support arm wheel to face of forks	x	mm	See battery compartment table		
	1.9	Wheelbase	y	mm	1295	1515	1575
	Weight	2.1	Service weight including battery		kg	TBA	TBA
2.3		Axle load, mast retracted without load, drive/support arm wheel		kg	TBA	TBA	TBA
2.4		Axle load, mast extended with load, drive/support arm wheel		kg	TBA	TBA	TBA
2.5		Axle load, mast retracted with load, drive/support arm wheel		kg	TBA	TBA	TBA
Wheels		3.1	Drive/support arm wheel			Vulkollan ®	Vulkollan ®
	3.2	Wheel size, front		mm	Ø 350	Ø 400	Ø 400
	3.3	Wheel size, rear		mm	Ø 300	Ø 350	Ø 350
Dimensions	4.1	Tilt of fork, forward/backward	$\alpha/\beta$	deg	4°/-2° *)	4°/-2° *)	4°/-2° *)
	4.2	Height, mast lowered	$h_1$	mm	See mast dimensions table		
	4.3	Free lift	$h_2$	mm	See mast dimensions table		
		Lift height	$h_{23}$	mm	See mast dimensions table		
	4.5	Height, mast extended	$h_4$	mm	See mast dimensions table		
		Height with navigation scanner	$h_{20}$	mm	3032 *)	3032 *)	3032 *)
		Height eye navigation scanner	$h_{21}$	mm	3000 *)	3000 *)	3000 *)
	4.7	Height of overhead guard (cab)	$h_6$	mm	2198	2260	2260
	4.15	Height of lowered forks	$h_{13}$	mm	40 *)	40 *)	45 *)
	4.20	Length to face of forks	$l_2$	mm	See battery compartment table		
	4.21	Overall width	$b_1$	mm	1270/1470/1670 *)	1270/1470/1670 *)	1270/1470/1670 *)
		Distance between support arms	$b_4$	mm	900/1100/1300	900/1100/1300	900/1100/1300
	4.31	Ground clearance, with load, below mast	$m_1$	mm	68	68	88
4.32	Ground clearance, centre of wheelbase	$m_2$	mm	74 *)	77 *)	77 *)	
Performance data	5.1a	Travel speed, automatic mode		km/h	5,4	5,4	5,4
	5.1b	Travel speed, manual mode		km/h	5,4	5,4	5,4
	5.2	Lift speed, with/without load		m/s	0,35/0,70	0,35/0,70	0,35/0,70
	5.3	Lowering speed, with/without load		m/s	0,55/0,55	0,55/0,55	0,55/0,55
	5.10	Service brake			Electric	Electric	Electric
Electric motor	6.1	Drive motor rating S2 60 min		kW	7,5	9,0	9,0
	6.2	Lift motor rating S3 15%		kW	11,0	15,0	15,0
	6.4	Battery voltage, nominal capacity $K_5$		V/Ah	48 / See battery compartment table		
	6.5	Battery weight		kg	552	719	903
	6.6	Energy consumption acc to VDI cycle <sup>3)</sup>		kWh/h			
	Other	8.1	Type of drive control			Variable AC	Variable AC

1) Excl. side sensors.

2) Excl. optional foot protection.

3) Contact your supplier for more information.

\*) Other alternatives are available.

All data are based on table configuration. Other configurations may give other values.

Truck performance and dimensions are nominal and subject to tolerances.

BT products and specifications are subject to change without notice.

# Battery dependent dimensions

Dimensions					RRE160			RRE200			RRE250	
Reflex	Depth		mm		275	347	419	347	419	491	419	491
	1.8	Load distance, centre of support arm wheel to face of forks	x	mm	347	275	203	352	280	208	335	263
	4.20	Length to face of forks, integrated safety scanner	$l_2$	mm	1250	1322	1394	1425	1497	1596	1502	1574
	4.20	Length to face of forks, external safety scanner	$l_2$	mm	1400	1472	1544	1575	1647	1719	1652	1724
6.4	Battery voltage, nominal capacity $K_5$		V/Ah		465	620	775	620	775	930	775	930

# Mast dimensions, mm

Mast				Triplex Hilo mast										
	Lift height	$h_{23}$	mm	4800	5400	5700	6300	7000	7500	8000	8500	9000	9500	10000
	Lift	$h_3$	mm	4760	5360	5660	6260	6960	7460	7960	8460	8960	9460	9960
RRE160	Height, mast lowered	$h_1$	mm	2281	2481	2500	2781	3074	3241	3408	3574	3741	3908	4300
	Free lift	$h_2$	mm	1291	1491	1449	1791	2023	2190	2357	2523	2690	2857	3942
	Height, mast extended	$h_4$	mm	5391	5981	6350	6891	7650	8150	8650	9150	9650	10150	10650
RRE200	Height, mast lowered	$h_1$	mm	2281	2481	—	2781	3014	—	3348	3514	3681	3848	4014
	Free lift	$h_2$	mm	1291	1491	—	1791	2025	—	2357	2525	2691	2857	3025
	Height, mast extended	$h_4$	mm	5391	5981	—	6891	7591	—	8591	9091	9591	10091	10591
RRE250	Height, mast lowered	$h_1$	mm	2281	2481	—	2781	3014	—	3348	3514	3681	3848	4014
	Free lift	$h_2$	mm	1291	1491	—	1791	2025	—	2357	2525	2691	2857	3025
	Height, mast extended	$h_4$	mm	5391	5981	—	6891	7591	—	8591	9091	9591	10091	10591

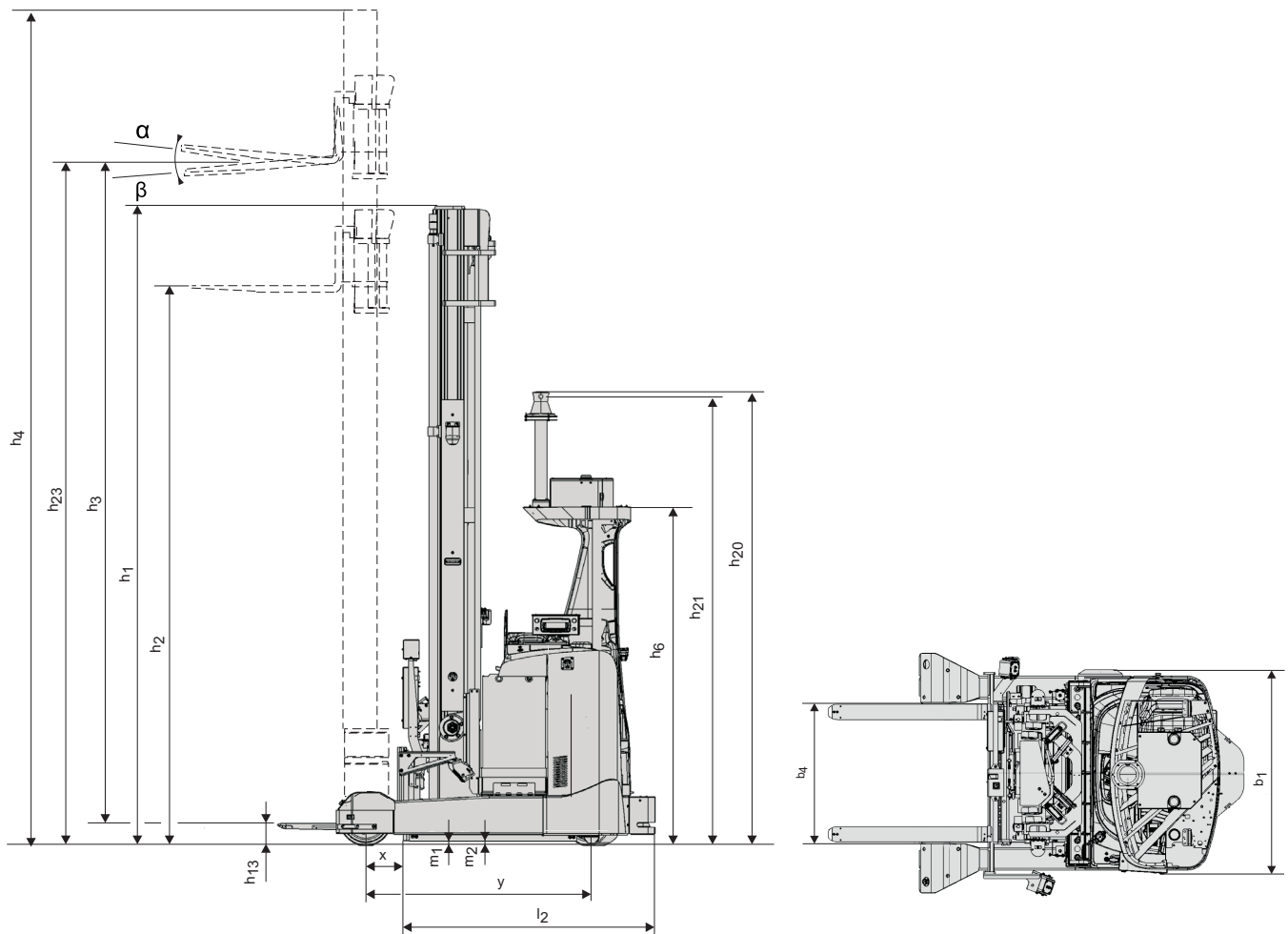

---

## Truck features:

- Automatic
  - loading and unloading
  - horizontal transport
  - vertical stacking
  - horizontal deep stacking
- Manual handling
- Laser precision navigation
- Personal safety protection drive direction
- Personal safety protection fork direction
- Side sensors
- Obstacle detection system (optional)
- Slot detection (optional)
- Load detection
- Information display
- Advanced vision system (optional)
- Electronically regenerative braking system

