

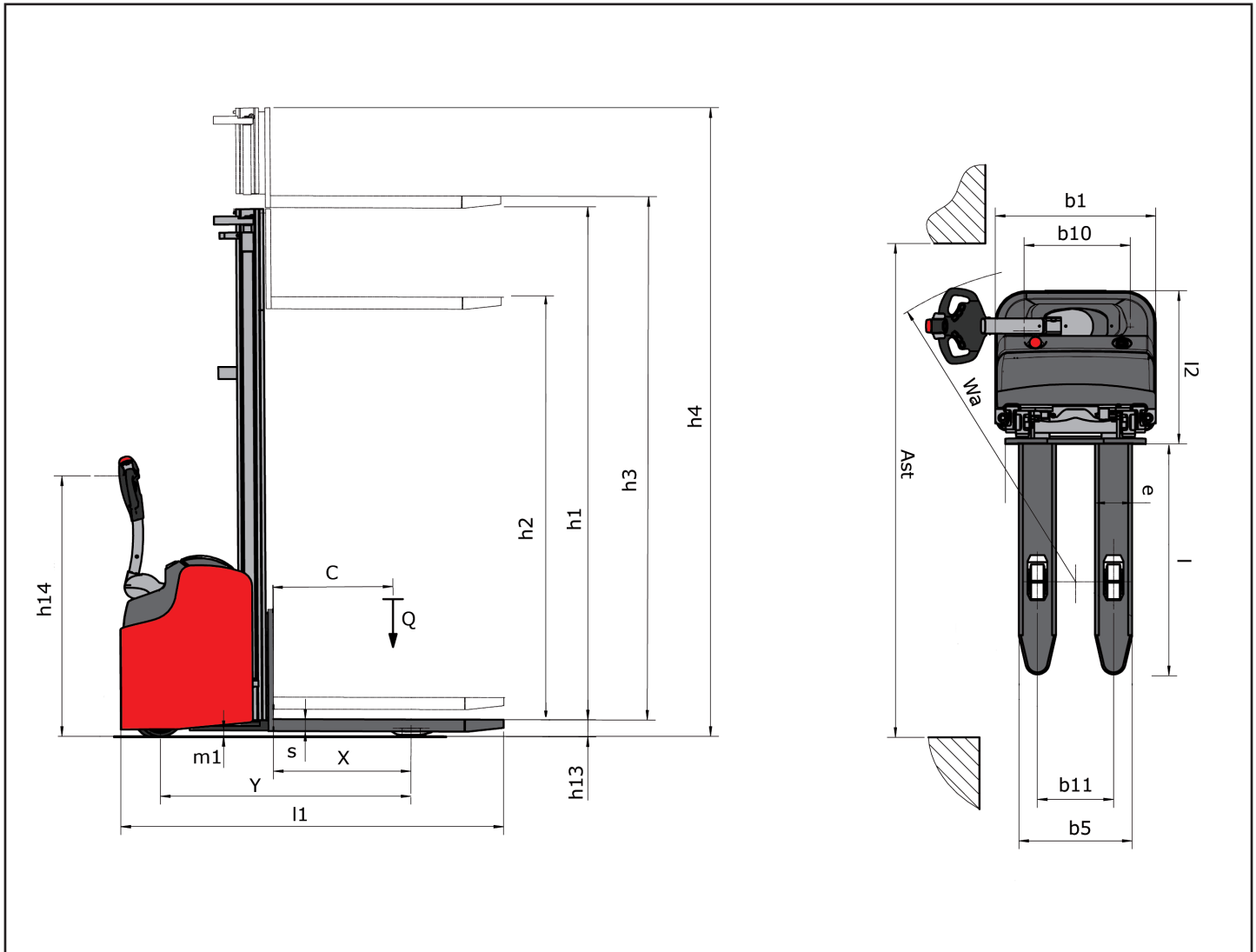

				MANITOU	MANITOU	MANITOU	MANITOU
				ES410 ET	ES410	ES412 ET	ES412
		Q	kg	1000	1000	1200	1200
		c	mm	600	600	600	600
		x	mm	723	723	683	683
		y	mm	1285	1285	1245	1245
			kg	870	870	874	874
			kg	709/1161	709/1161	729/1342	729/1342
			kg	609/261	609/261	612/262	612/262
			mm	1x(Ø230x75)	1x(Ø230x75)	1x(Ø230x75)	1x(Ø230x75)
			mm	2x(Ø78x78)	2x(Ø78x78)	4x(Ø82x70)	4x(Ø82x70)
			mm	1x(Ø125x50)	1x(Ø125x50)	1(Ø125x50)	1x(Ø125x50)
				1x1/2	1x1/2	1x1/4	1x1/4
		b10	mm	517	517	517	517
		b11	mm	380	380	380	380
		h1	mm	1930	1940	1930	1940
		h2		140	-	140	-
		h3		2930*	2940*	2930*	2940*
		h4		3365	3365	3365	3365
		h14	mm	-	-	-	-
		h13	mm	85 <sup>+5 -0</sup>	85 <sup>+5 -0</sup>	85 <sup>+5 -0</sup>	85 <sup>+5 -0</sup>
		l1	mm	1870	1870	1870	1870
		l2	mm	720	720	720	720
		b1	mm	800	800	800	800
		s / e / l	mm	60x180x1150	60x180x1150	60x180x1150	60x180x1150
		b3		680	680	680	680
		b5	mm	560	560	560	560
		m1		35	35	35	35
		m2	mm	20	20	20	20
		Ast	mm				
		Ast	mm	2287	2287	2222	2222
		Wa	mm	1465	1465	1400	1400
			km/h	6/6	6/6	6/6	6/6
			m/s	0,11/0,16	0,14/0,24	0,10/0,16	0,12/0,24
			m/s	0,14/0,12	0,30/0,20	0,14/0,12	0,30/0,20
			%	8/10	8/10	8/10	8/10
			kW	1	1,2	1	1,2
			kW	2	3	2	3
			V/Ah	26/160**	24/180**	24/160**	24/180**
			kg	139		139	
			db (A)	65	65	65	65

\*  
\*\*



ES 410 - ES 412								
		D29	D34	D38	D43	DLL 29	DLL 34	TLL 42
h3	mm	2940	3440	3840	4340	2935	3435	4240
h1	mm	1940	2190	2390	2640	1940	2190	1960
h2	mm	-	-	-	-	1510	1760	1470
h4	mm	3365	3865	4265	4765	3365	3865	4730

ES 410 ET - ES 412 ET						
		SVC 15	SVC 17	DVC 26	DVC 29	DVC 34
h3	mm	1510	1760	2630	2930	3430
h1	mm	1940	2190	1780	1930	2180
h2	mm	1510	1760	140	140	140
h4	mm	1940	2190	3065	3365	3865

