

MSI 20/25/30/35 T MSI 20/25/30 G



Tragkraft

bei 500 mm LSpA :

MSI 20 T/G.....	2000 kg
MSI 25 T/G.....	2500 kg
MSI 30 T/G.....	3000 kg
MSI 35 T.....	3500 kg



Standardhubhöhe.....3,30 m



Bereifung

Vorne.....275/70 R 22,5 RHS
Hinten.....7.00 x 12 14 PR IC 40



Gabelzinken (mm)

Länge.....1100
Breite x Dicke100 x 45
Maximaler Abstand an der Außenkante1260



Hydraulische Bremsanlage Negativ Bremse



Motor Kubota

Typ.....V 2403-M-T- E3B
Hubraum4 Zylinder 2434 cm³
Leistung (ISO 3046).....60 PS/44 kW
Maximales Drehmoment :165 Nm at 1600 rpm
Indirekteinspritzung
Wasserkühlung

GPL Toyota Motor

MSI 20 G/25 G/30 G.....Typ : 4 Y
Hubraum4 Zylinder 2237 cm³
Leistung (ISO TR 14396)53 PS/39 kW
Maximales Drehmoment :162 Nm bei 1800 U/mn
Wasserkühlung



Hydrostatische Kraftübertragung REXROTH

Antriebsräder.....2
Elektrohydraulischer Fahrtichtungsschalter
Vorwärts- / Rückwärtsgänge.....1/1
Maximale Fahrgeschwindigkeit20 km/h
Steigfähigkeit unbelastet
MSI 20/25/30/35 T.....33/31/24/29%
Steigfähigkeit belastet
MSI 20/25/30/35 T.....37/32/29/29%



Hydraulik

Zahnradpumpe.....125 bars/77 l/mn



Füllmengen

Kühlsystem.....10 l.
Motoröl9,5 l.
Hydrauliköl95 l.
Kraftstoff73,5 l.



Eigengewicht (mit Gabeln)

MSI 20/25/30/35 T.....3860/4160/4820/4980 kg
MSI 20/25/30 G.....3470/4045/4425 kg

Gesamtbreite1,32 m

Gesamthöhe2,30 m

Gesamtlänge.....4,04/4,04/4,08/4,13 m

Bodenfreiheit.....215 mm

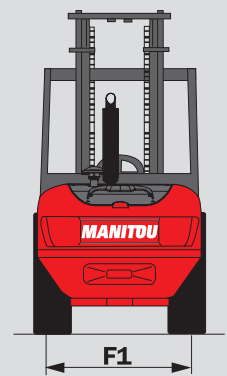
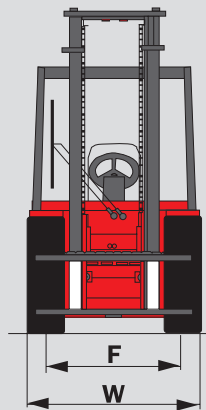
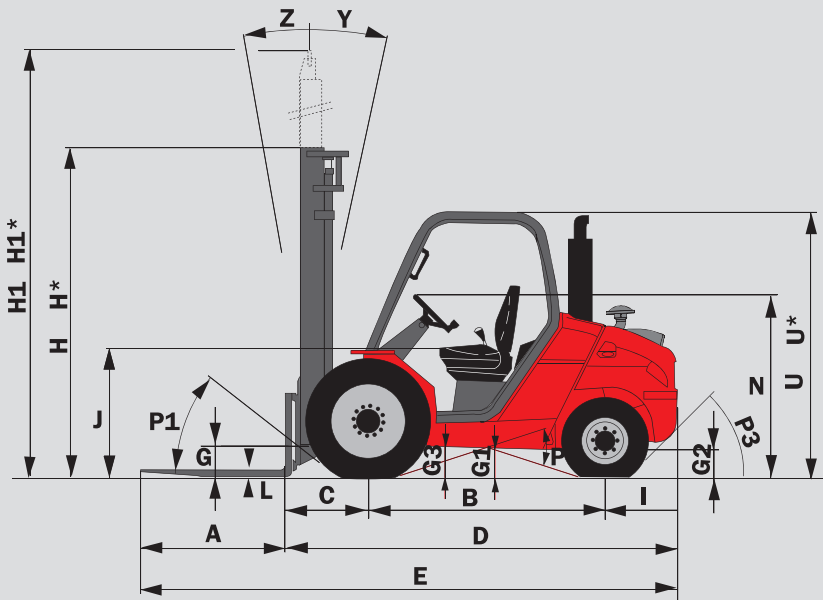

	MSI 20 T/G +BUGGIE	MSI 25 T/G +BUGGIE	MSI 30 T/G +BUGGIE	MSI 35 T +BUGGIE
A	1100	1100	1100	1100
B	1800	1800	1800	1800
C	625	625	630	630
D	2945	2945	2980	3030
E	4045	4045	4080	4130
F	1046	1046	1046	1046
F1	1102	1102	1102	1102
G	270	270	270	270
G*	240	240	240	240
G1	260	260	260	260
G1*	260	260	260	260
G2	215	215	215	215
G2*	230	230	230	230
G3	270	270	270	270
H	2300	2300	2300	2300
H*	1950	1950	2050	2050
H1	4131	4131	4193	4193
H1*	4470	4470	4500	4500
I	520	520	550	600
J	1025	1025	1025	1025
K	1260	1260	1260	1260
L	40	40	45	45
N	1450	1450	1450	1450
O	100	100	100	125
P1	49,5°	49,5°	49,5°	49,5°
P2	40,5°	40,5°	40,5°	49,5°
P3	44°	44°	40°	40°
R	2310	2310	2310	2330
S	2545	2545	2580	2590
T	4525	4525	4560	4595
U	2105	2105	2105	2105
U*	1990	1990	1990	1990
V	2600	2600	2635	2665
V1	150	150	150	100
W	1323	1323	1323	1323
Y	12°	12°	12°	12°
Z	10°	10°	10°	10°

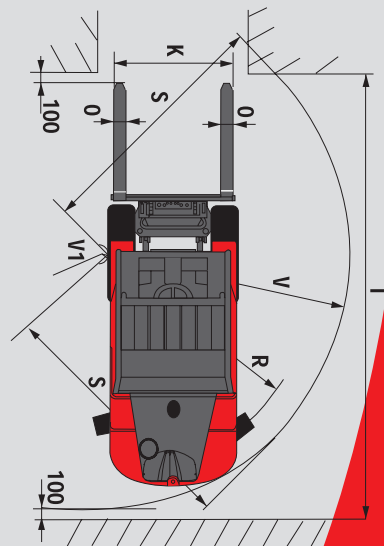

Änderungen im Sinne des technischen Fortschritts vorbehalten.
Die in der Vorliegenden Broschüre vorgestellten MANITOU - Maschinen können mit Zusatzgeräten ausgestattet sein.

H - H1 - R = Standard
H*-(Triplex 3,70 m) H1* = Option

U* = MSI 20/25 BUGGIE
G* - G1* - G2* = mit Last



Deutschland und Österreich : MANITOU Deutschland GmbH

61239 OBER-MÖRLEN ☎ 49 6002 - 9199 - 0

Andere Länder : MANITOU B.F. S.A.

44158 ANCENIS CEDEX - FRANKREICH ☎ 33 2 40 09 10 11

www.manitou.com

700314DE-C - 10/08

