



**STRONG PARTNERS. TOUGH TRUCKS.**

## **Empty Container Handlers H16.00-22.00XM-12EC**

7 000 - 9 000 kg @ 1220 mm



# Hyster Empty Container Handlers H16.00-22.00XM-12EC

CHARACTERISTICS	1.1	Manufacturer	
	1.2	Model designation	
	1.3	Power: battery, diesel, LPG, electric mains	
		Container Stacking Height, containers of 8' 6" high / containers of 9' 6" high	
	1.5	Load capacity	Q (kg)
	1.6	Load centre	c (mm)
	1.8	Load distance, spreader with Mechanical Articulation / spreader with Powered Pile Slope (PPS)	x (mm)
	1.9	Wheelbase	y (mm)

HYSTER		HYSTER		HYSTER	
H16.00XM-12EC Single Empty Container Handler		H18.00XM-12EC Single Empty Container Handler		H18.00XM-12EC Single Empty Container Handler Increased Capacity	
Diesel		Diesel		Diesel	
6 high 8'6"		7 high 8'6"		7 high 8'6"	
5 high 9'6"		6 high 9'6"		6 high 9'6"	
7 000		7 000		8 500	
1 220		1 220		1 220	
1 310	1 394	1 310	1 394	1 310	1 394
4 000		4 500		4 500	

WEIGHTS	2.1	Unladen weight, with pneumatic tyres, without PPS	kg
	2.2	Axle loading with load, front/rear	kg
	2.3	Axle loading without load, front/rear	kg

32 300		32 970		32 970	
32 785	6 515	32 875	7 095	35 530	6 135
21 350	10 950	21 935	11 035	21 935	11 035

WHEELS & TYRES	3.1	Tyres: L=pneumatic, V=solid, SE=pneumatic-shaped solid	
	3.2	Tyre size, front	inch
	3.3	Tyre size, rear	inch
	3.5	Number of wheels, front/rear (X = driven)	
	3.6	Track width, front	b <sub>10</sub> (mm)
	3.7	Track width, rear	b <sub>11</sub> (mm)

L		L		L	
14.00 x 24		14.00 x 24		14.00 x 24	
14.00 x 24		14.00 x 24		14.00 x 24	
4X	2	4X	2	4X	2
3 286		3 286		3 286	
2 356		2 356		2 356	

DIMENSIONS	4.1	Mast tilt, α = forward/β = back	degrees
	4.2	Height of mast, lowered	h <sub>1</sub> (mm)
	4.3	Spreader, min. distance to engagement point	h <sub>2</sub> (mm)
	4.4	Lift height ◆	h <sub>3</sub> (mm)
	4.5	Maximum height, top of spreader, with Vertical Twistlocks	h <sub>4</sub> (mm)
	4.7	Height of basic truck (without mast), cab/exhaust ■	h <sub>6</sub> / h (mm)
	4.8	Seat height	h <sub>7</sub> (mm)
	4.20	Length to load face of spreader, without PPS	l <sub>2</sub> (mm)
	4.21	Overall width over front tyres	b <sub>2</sub> (mm)
	4.31	Ground clearance under mast (with load)	m <sub>1</sub> (mm)
	4.32	Ground clearance, centre of wheelbase	m <sub>2</sub> (mm)
	4.34	90° Stacking Aisle 20' / 40', without operating clearance	V (mm)
		90° Stacking Aisle 20' / 40', with 200mm operating clearance	Ast (mm)
		90° Stacking Aisle 20' / 40', with 10% operating clearance according FEM TN01	Ast (mm)
	4.35	Outer turning radius	W <sub>a</sub> (mm)

4	4	4	3	4	3
9 460		10 760		10 760	
2 295		2 295		2 295	
13 850		16 450		16 450	
16 565		19 165		19 165	
3 810	4 425	3 810	4 425	3 810	4 425
2 625		2 625		2 625	
6 126		6 626		6 626	
4 120		4 120		4 120	
299		299		299	
357		357		357	
9 410	13 750	9 890	V (mm)	9 890	13 750
9 610	13 950	10 090	13 950	10 090	13 950
10 350	15 120	10 880	15 120	10 880	15 120
5 440		6 060		6 060	

PERFORMANCE	5.1	Travel speed with load / without load - with 145 kW engine	kp/h
		Travel speed with load / without load - with (optional) 172 kW engine	kp/h
	5.2	Lifting speed with/without load, with 145 kW engine	m/sec
		Lifting speed with/without load, with (optional) 172 kW engine	m/sec
	5.3	Lowering speed with/without load	m/sec
	5.6	Maximum drawbar pull with load, with 145 kW / (optional) 172 kW engine	kN
	5.7	Gradeability with load, @ 1.6 km/h, with 145 kW / (optional) 172 kW engine †	%
	5.8	Maximum gradeability with load, with 145 kW / (optional) 172 kW engine	%
5.10	Service brake		

27	30	27	30	-	-
26	28	-	-	26	28
0,52	0,56	0,52	0,56	-	-
0,52	0,55	-	-	0,52	0,55
0,49	0,47	0,49	0,47	0,49	0,47
110	163	110	-	-	163
23	34	23	-	-	34
29	44	29	-	-	44
Oil immersed brakes		Oil immersed brakes		Oil immersed brakes	

ENGINE	7.1	Engine manufacturer/type	
	7.2	Engine performance	kW (Hp)
	7.3	@ engine speed	rpm
	7.4	Number of cylinders/displacements	cm <sup>3</sup>
	7.5	Fuel consumption for medium to heavy duty use, with 145 kW / (optional) 172 kW engine	l/h

Cummins QSB 6		Cummins QSB 6		Cummins QSB 6	
145 kW (197 Hp)		145 kW (197 Hp)		172 kW (230 Hp)	
option 172 kW (230 Hp)					
1 800		1 800		1 800	
6	6 700	6	6 700	6	6 700
☎	☎	☎	☎	☎	☎

OTHER	8.1	Drive control	
	8.2	Pressure for attachments	bar
	8.3	Oil flow for attachments	l/min
	8.4	Average noise level, operator's ear, BITA Leq / EN12053	dB (A)
	8.5	Towing coupling type	

3-speed autoshift SOH TE13 optional SOH TE17		3-speed autoshift SOH TE13		3-speed autoshift SOH TE17	
189		189		189	
105		105		105	
72	73	72	73	72	73
-		-		-	

Specification data is based on VDI 2198

HYSTER		HYSTER		
H22.00XM-12EC Double Empty Container Handler		H22.00XM-12EC Double Empty Container Handler		1.1
Diesel		Diesel		1.2
2 on 5 high 8'6"		2 on 6 high 8'6"		1.3
2 on 4 high 9'6"		2 on 5 high 9'6"		
9 000		9 000		1.5
1 220		1 220		1.6
1 310	1 394	1 310	1 394	1.8
4 500		4 500		1.9

CHARACTERISTICS

35 340		35 950		2.1
36 110	8 230	36 780	8 170	2.2
22 045	13 295	22 720	13 230	2.3

WEIGHTS

L		L		
14.00 x 24		14.00 x 24		3.1
14.00 x 24		14.00 x 24		3.2
4X	2	4X	2	3.3
3 286		3 286		3.5
2 356		2 356		3.6
				3.7

WHEELS & TYRES

4	3	4	3	4.1
9 460		10 760		4.2
2 295		2 295		4.3
13 850		16 450		4.4
16 565		19 165		4.5
3 810	4 425	3 810	4 425	4.7
2 625		2 625		4.8
6 626		6 626		4.20
4 120		4 120		4.21
299		299		4.31
357		357		4.32
9 890	13 750	9 980	13 750	4.34
10 090	13 950	10 090	13 950	
10 880	15 120	10 880	15 120	
6 060		6 060		4.35

DIMENSIONS

-	-	-	-	5.1
26	28	26	28	5.2
-	-	-	-	
0,52	0,55	0,52	0,55	5.3
0,49	0,47	0,49	0,47	5.4
-	166	-	166	5.6
-	27	-	27	5.7
-	35	-	35	5.8
Oil immersed brakes		Oil immersed brakes		5.10

PERFORMANCE

Cummins QSB 6		Cummins QSM 11		7.1
172 kW (230 Hp)		172 kW (230 Hp)		7.2
1 800		1 800		7.3
6	6 700	6	10 800	7.4
☎	☎	☎	☎	7.5

ENGINE

3-speed autoshift SOH TE17		3-speed autoshift SOH TE17		8.1
189		189		8.2
105		105		8.3
72	73	72	73	8.4
-		-		8.5

OTHER

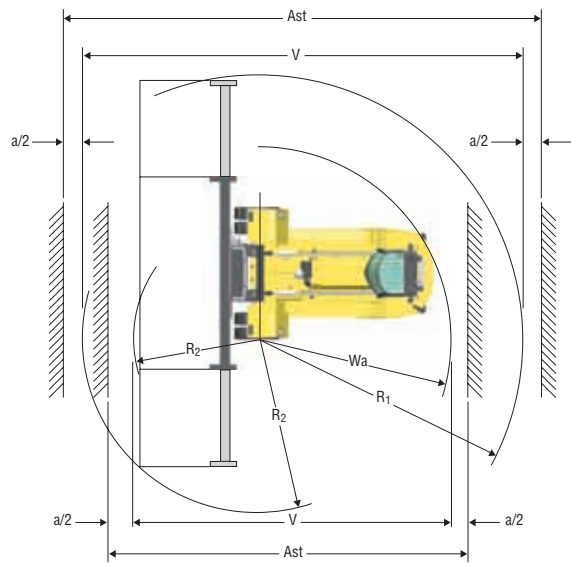
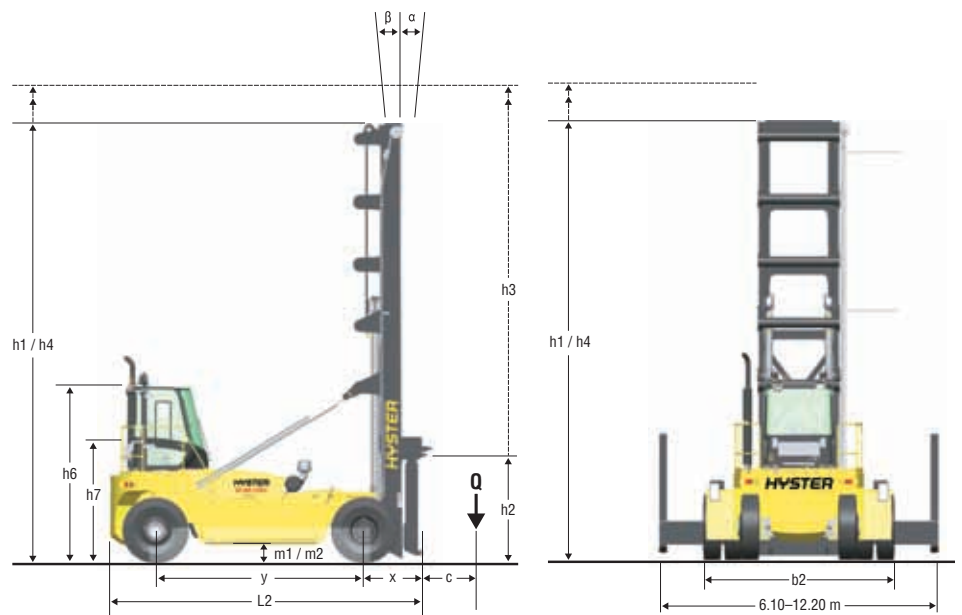

$A_{st}$  = Practical 90 degrees Stacking aisle  
 $= V$  (theoretical stacking aisle) +  $a$  (total operating clearance)  
 Where  $V = R_2 +$  the larger of  $R_1$  or  $W_a$   
 $a = 200$  mm (100 mm each side acc. VDI)  
 or:  
 $a = 10\%$  of  $V$  (acc. FEM TN01 recommendation). See line 4.34

† Gradeability figures (lines 5.7 & 5.8) are provided for comparison of tractive performance, but are not intended to endorse the operation of the vehicle on the stated inclines. Follow instructions in the operating manual regarding operation on inclines.

- ◆ Bottom of forks
- With non-sideshift carriage
- ☎ Consult your Hyster lift truck dealer





# Models, stacking heights and capacities







The Hyster Empty Container Handlers range H16.00-22.00XM-12EC consists of following models:

- > **H16.00XM-12EC** Empty Container Handler, maximum 7000 kg,
  - > stacking **6 x 8'6"** high or 5 x 9'6" high **single** containers.
- > **H18.00XM-12EC** Empty Container Handler, maximum 7000 kg,
  - > stacking **7 x 8'6"** high or 6 x 9'6" high **single** containers.
- > **H22.00XM-12EC** Empty Container Handler, maximum 9000 kg,
  - > stacking **'2 on 5' x 8'6"** high or '2 on 4' x 9'6" high **double** containers,
  - > and also: 6 x 8'6" high or 5 x 9'6" high single containers.
- > **H22.00XM-12EC** Empty Container Handler, maximum 9000 kg,
  - > stacking **'2 on 6' x 8'6"** high or '2 on 5' x 9'6" high **double** containers,
  - > and also: 7 x 8'6" high or 6 x 9'6" high single containers.

All capacities are according to ISO 10525.

Warning: Care must be exercised when handling elevated loads. When the carriage and/or load is elevated, truck stability is reduced. It is important that mast tilt be kept in back-tilted position or maximum in vertical position when mast / loads are elevated. Operators must be trained and adhere to the instructions contained in the Operating Manual.



Container Stacking		Hyster Model	Spreader engagement	Spreader (sideways) articulation	Capacity kg @ 1220mm
	SINGLE containers 6 x 8'6" or 5 x 9'6"	<b>H16.00XM-12EC</b> with 13.85m lift mast	Verticle Twistlocks 	Free (mechanical) articulation	7000
	SINGLE containers 7 x 8'6" or 6 x 9'6"	<b>H18.00XM-12EC</b> with 16.45m lift mast	or: Suspended Hooks 	Free (mechanical) articulation or: (hydraulic) Powered Pile slope	7000 *) 8500 **)
*) 7000 kg with (standard) 145 kW / 195 Hp engine. **) 8500 kg with (optional) 172 kW / 230 Hp engine.					
Container Stacking		Hyster Model	Spreader engagement	Spreader (sideways) articulation	Capacity kg @ 1220mm
	DOUBLE containers 2 on 5 x 8'6" or 2 on 4 x 9'6"	<b>H22.00XM-12EC</b> with 13.85m lift mast	Hooks & Side Clamps 	Free (mechanical) articulation or: (hydraulic) Powered Pile slope	9000
	DOUBLE containers 2 on 6 x 8'6" or 2 on 5 x 9'6"	<b>H22.00XM-12EC</b> with 16.45m lift mast	or: Double Horizontal Twistlocks 	(hydraulic) Powered Pile slope	9000





## Built On Experience

The H16.00-22.00XM-12EC series benefit from Hyster's long experience in designing and building high-stacking empty container handlers. These EC handling machines offer fastest handling, reliable proven components, and give an excellent return on your investment.

Increased handling flexibility is provided by Hyster's empty container handling spreader, featuring 'reefer correction' as standard, and a choice of four different container engagement systems, for fast handling of single or double containers.

This will ensure that Hyster continues to meet your needs for increased productivity and lowest cost of ownership.





## Extra Value Features

The H16.00-22.00XM-12EC range offers impressive extra value, in an all-in-one package:

- › **Lifting speeds** are class leading: The practical 4-mode average speed is a fantastic 0.51 m/sec, and this even when handling double containers!
- › The unique **Hyster '1 to 4' lift ratio mast** contributes to the high lift speeds, and features short and stable lift cylinders.
- › **Stable** machine with a weight of 32 to 36 tons, a wheelbase of 4.0 or 4.5 m, and a width of 4.12 m.
- › **Rear-mounted cab** for a more comfortable view angle during high stacking of containers.
- › Hyster **'Vista'** cab is state of the art in driver comfort, ergonomics, low noise and visibility. Air conditioning is standard. Noise level is just 73 dB(A) Leq at driver's ear. The cab has powered tilt backwards, for easy service access.
- › Big 6.7 litre, cleaner running Cummins diesel engine conforms to stringent EC **Tier 3** emission regulations.
- › The 3-speed **auto-shift** transmission has a protective lock-out on forward-reverse shifting.
- › Strong and wide AxleTech drive axle with **oil-immersed** (wet) disc brakes.
- › Engine and transmission **protection** systems.
- › **Tropical cooling** package, for working in ambients of up to 50° C., is standard.
- › Hyster ECH side-lift container spreader comes standard with **'reefer correction'** and a choice of **four 'container engagement' systems**. Twistlock indicator lights, on the spreader and in the cab roof are standard equipment (not on 'Suspended Hooks' version).
- › Large **14.00 x 24** tyres as standard, for improved tyre life and lower running costs.



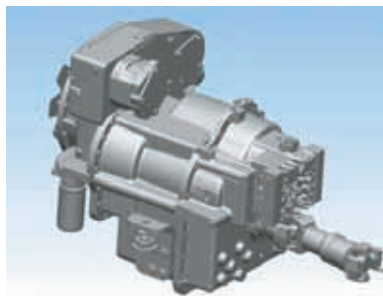

## Strength & Durability

- › The frame is immensely strong with 16 mm thick frame members and massive front axle supports. The tilt cylinder anchors are tied directly into the rear frame.
- › The AxleTech drive axle is ultra-wide (4.12 m over tyres) and provides stability and durability; whilst the oil immersed (wet) disc brakes reduce maintenance requirements.
- › The S.O.H. TE-series 3-speed powershift transmission has APC200 Soft-shift automatic gear shifting, a protective forward-reverse shifting lock-out, and a transmission protection device.
- › Hyster's 'sandwich' type steer axle, with a single cylinder and non-adjustable tie rods is renowned for its long life and low maintenance.
- › Large 14.00 x 24 wheels on all models, offer long tyre life for low running costs.



## Power & Performance

Clean engine power is provided by the 6.7 litre 6-cylinder Cummins QSB6 industrial diesel, with turbo-charger and charge air cooler.

- › The low exhaust emissions conform to the EC Tier 3 emissions standard for NRMM (Non-Road Mobile Machinery).
- › The industrial rating offers extra durability for long periods of peak power operation.
- › Engine protection system, with initial engine derating and finally engine stop function.
- › Equipped with a two-stage heavy-duty air filter, plus a maintenance-free cyclonic pre-cleaner, suitable for dusty operating environments.
- › Fuel tank 367 litres.
- › Anti-corrosive (aluminized steel) exhaust system.

- › **H16.00-18.00XM-12EC** Single container handlers: Engine performance is **145 kW / 197 Hp** @ only 1800 rpm, maximum torque is 931 Nm @ 1400 rpm.

This 145 kW engine is combined with the S.O.H. (Spicer Off-Highway) TE-13 powershift transmission, with 3-speeds with APC200 “Soft-shift” automatic gear shifting, protective forward-reverse shifting lock-out, and transmission protection system. Also fitted is a specific oil cooler. Audible alarm when in reverse gear.

- › **H22.00XM-12EC** Double container handlers: **172 kW / 230 Hp** @ only 1800 rpm, maximum torque is 938 Nm @ 1400 rpm. Combined with the S.O.H. (Spicer Off-Highway) TE-17 3-speed powershift transmission, also with APC200 “Soft-shift” auto shift, forward-reverse lock-out, and transmission protection. Dedicated oil cooler, audible alarm in reverse.

- › Optional power package for H16.00-18.00XM-12EC Single container handlers: the 172 kW engine and TE-17 transmission package, instead of the standard 145 kW and TE-13 combination.



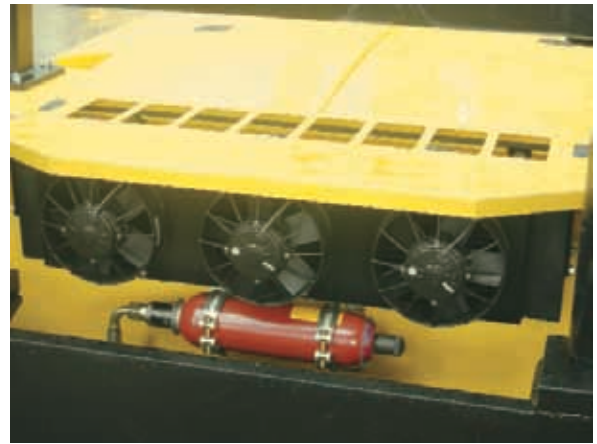

### Cool

- › The H16.00-22.00XM-12EC machines have a tropical cooling system which makes them suitable to work in ambient temperatures up to 50°C.
- › The unique 'side-by-side' 3-piece radiator cooler block for engine (water and intercooler) and transmission is efficient and easy to clean. A 'puller' type fan draws in cleaner air from the top of the machine.
- › A triple hydraulic system cooler, for the brakes and the hydraulic system is mounted at the front of the machine.

### Fast

- › Lifting speeds are class leading: The practical 5-mode average lifting speed is a fantastic 0.51 m/sec. And this also when handling double containers. Average of five lifting modes:
  - unladen lift speed = 0.55 m/sec.
  - full laden lift speed = 0.52 m/sec.
  - 70% laden load lift speed = 0.54 m/sec.
  - unladen lowering speed = 0.47 m/sec.
  - laden lowering speed = 0.49 m/sec.
- › Travel speeds are very productive too, with a maximum of 26 to 30 km/h., depending on model and engine choice.





## Ergonomic Design

The EC series features the Hyster 'Vista' cab, which gives the optimum ergonomic operator environment, and focuses on maximising driver comfort and visibility for maximum productivity.

- › The large windows, fitted with tinted safety glass, offer excellent all-round visibility. This is further enhanced by a filtered fresh air inlet, sliding windows, an effective heater and defrosters, wipers with washers on front, top and rear screens, especially in poor weather conditions
- › Air-conditioning is integrated into the heating and ventilation system, with manual temperature control. Sunshade screens are fitted on the top and rear windows.
- › Newly designed joystick gives intuitive control of mast lift, tilt and spreader functions: Sideshift, Telescope 20'-40', Optional PPS, Twistlocks unlocking (locking is automatic).
- › Full-suspension, fully adjustable driver's seat with a high backrest, seat belt, seat switch for park brake warning buzzer and operator presence system.
- › Map reading light, extra air circulation fan.
- › Adjustable steering column, power-assisted steering and lever controls, push-button parking brake and conveniently positioned instruments.
- › Responsive, fully hydraulic brakes and automotive type pedal layout further contribute to driver comfort.
- › Rear view mirrors inside the cab, and extra rear view mirrors on the front fenders.
- › The comprehensively equipped operator's cab, mounted on isolators, has an insulated twin-layer floor to help achieve low noise levels. The noise level is just 73 dB(A) Leq at driver's ear.



## Outstanding Visibility

- › The operator compartment is mounted at the rear of the machine, for a comfortable view angle during high stacking of containers.
- › Available on both the 5/6-high stackers (H16.00XM-12EC, 4.0 m wheelbase) and the 6/7-high stackers (H18.00-22.00XM-12EC, 4.5 m wheelbase) where the cab is an extra 0.5 m to the rear.
- › Operator visibility during high stacking from the rear-mounted cab position, is also enhanced by the curved front window, the strong yet slim line cab construction, the 'wave pattern' overhead guard, plus wipers on the front, top and rear screen (with double blade at the front).
- › The ultra-wide mast (1260 mm between inner channels) adds to the excellent overall visibility.
- › The lift cylinders are also uniquely rear-mounted (behind the mast channels) for optimum visibility.
- › Indicator lights for the container engagement functions are mounted on the spreader and also conveniently placed in the cab's roof. (except for spreader with 'Suspended Hooks').
- › The 'state of the art' Hyster 'Vista' cab is equipped with air conditioning and sliding sunshade screens on the top and rear window.
- › Rear view mirrors inside the cab, and extra rear view mirrors on the front fenders.
- › The truck is equipped with a comprehensive set of road and work lights and an orange strobe light. See full details under lights.









## Unique '1 to 4' Hyster 'Vista' Mast

- › Ultra-wide mast construction, for torsional rigidity and also excellent visibility (distance of 1260 mm in between the inner mast channels).
- › This stable Hyster 'Vista' mast has a unique '1 to 4' lift ratio. On these EC trucks with their extremely high lift heights, the Hyster '1 to 4' design results in halving the length of the lift cylinders, thereby offering excellent durability of the cylinder bearings and seals.
- › The tilt cylinders are high-mounted on the mast for added rigidity and truck stability.
- › A hydraulic accumulator in the hoist system, to cushion the load carried, is standard equipment.



## Spreader Characteristics

Hyster ECH side-lift 20'-40' telescopic **spreader characteristics:**

- › Low profile main beam, with the horizontal telescoping beams sliding inside each other (not stacked on top of each other). This design results in excellent forward visibility towards the spreader's engagement points, particularly at high lift heights.
- › **Sideshift** movement is a generous +/- 600 mm (1200 mm total) for operational flexibility and provides for 'reefer correction' possibility.
- › **Spreader 'Articulation'**: Ample mechanical sideways articulation, by the 225 mm floating (up/down) movement of the spreader engagement heads. Facilitates handling of containers on / from a sloping surface.
- › 2 Wide-beam work lights on the spreader, pointing sideways to the spreader's engagement heads.

**Comprehensive indication and support systems:** (not on 'Suspended Hooks' engagement system)

- › **Indicator lights** (red, 2x orange and green) to signal spreader engagement, are on the **spreader and** in the **cab**.  
Orange left-hand = landed, Green = locked, Red = unlocked, Orange right-hand = landed.  
The lights panel in the cab roof also has a blue light signalling the mast lift interrupt function.
- › **Mast over-lowering interrupt** prevents further lowering of the mast when the spreader is landed on a container. The function is signalled by a blue warning light in the cab. To eliminate slacking of the header hoses, cables and lift-chains and to reduce shocks on the spreader.



For Twistlocks versions only:

› **Automatic locking.**

Automatically turns the (Vertical) twistlocks to the locked position when the spreader is properly landed on the container(s). Unlocking is always done manually by a switch in the cab.

› **Twistlocks interlock** (mechanical) to help prevent;

- a. Picking-up a container on less than 2 corners,
- b. Unlocking when carrying a container.

- › **Lift interrupt** cuts the lift mode if the twistlocks are not in a fully 'closed' / 'open' position. The function is signalled by a blue warning light in the cab.
- › Container counter on the spreader, recording the number of containers locked. This facility helps to measure productivity and to schedule periodic maintenance.



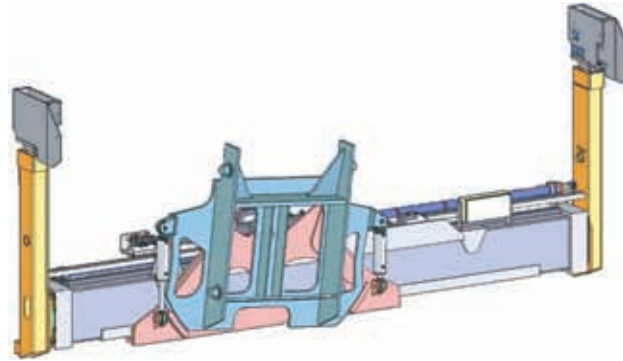

## Container Engagement Systems

The Hyster ECH side-lift 20'-40' telescopic spreader is available with a choice of four 'container engagement' systems, to suit individual user requirements:

To handle single containers:

### 1. Vertical twistlocks

Automatic twistlocks locking, Indicator lights, Twistlocks interlock function, Lift interrupt function, Container-counter.

### 2. Suspended hooks

Only the weight of the container maintains engagement by the hooks. Although hooks are suspended, it is necessary to handle the container with care, because of the likelihood of the container bouncing and disengaging from the hooks.

No indicator lights. No interlock function.

No lift interrupt.

For handling double (and single) containers:

### 3. Hooks and side-clamps

Hooks with additional Side-clamps, for one or two containers. Clamping function is non-automatic.

Clamps protrude 320 mm on each side of spreader. Not suitable for 45' container(s).

### 4. Double horizontal twistlocks

Spreader sides are 'flush' with container(s), allows entry into tightly spaced container block stacks.

Suitable for 45' containers with 40' ISO pockets.

Manual locking of four twistlocks, Twistlocks

interlock function, Lift interrupt function,

Container counter.

Optional: **PPS** (Powered Pile Slope) function

› PPS is a hydraulic powered sideways articulation of the ECH spreader, of +/- 6 degrees (in addition to the standard mechanical articulation).

› Application recommendations for a PPS function:

- Normally not required with 'Vertical Twistlocks', as this has a self-levelling handling characteristic by the lowering on to the top of a container.
- PPS function is convenient with 'Suspended Hooks' or with 'Hooks and Side-clamps', for easier engagement on to container(s).
- PPS function is mandatory with 'Double Horizontal Twistlocks', to facilitate easy engagement of four horizontal twistlocks.



## Other Features

### High performance hydraulics

- › Efficient and well-sized hydraulic components result in the fastest lifting speed: a tremendous 52 cm/sec. under full load. And this can be achieved with the smallest engine power (145 kW) available, providing excellent fuel efficiency.
- › An hydraulic accumulator in the hoist system cushions shocks caused by the vertical movement of the spreader and container(s), and helps to reduce dynamic peak loading on the lift chains.
- › Hydraulic oil tank with generous 400 litres.
- › Triple hydraulic oil cooler with ample capacity, mounted at the front of the machine.
- › Leak-free O-ring face hydraulic fittings

### Brakes

- › **Service brake:** front, oil-immersed (wet) disc brakes. Large oil cooler and a separate 10 micron brake oil filter. The brake system is fully hydraulic and charged by an accumulator (no air system).
- › **Parking brake:** spring actuated and hydraulically released, on the drive-line, automatically applied when pressure falls below 50 bar. The transmission is disengaged when the parking brake is applied.

### Wheels

- › Large 14.00 x 24 size tyres are fitted for improved tyre life and lower running costs.  
Bias pneumatic lug tread tyres are standard.  
Options: radial pneumatic lug tread tyres, or Solid (pneumatic shaped) lug tread tyres.
- › Note: an hydraulic accumulator in hoist system, which acts to cushion the load, is fitted with all tyre choices.

### Electrical system

- › 24 V system, 70 A alternator, Battery 102 Ah (20 hr).  
Battery master switch.
- › 'Canbus' connection in the cab, for engine, transmission, and instrument cluster.



### Lights

A complete light kit is fitted:

- › 4 front work lights (to 20' and 40' position) on the cab,
- › 2 front head lights on the front fenders,
- › 2 rear work/drive lights on the cab,
- › 2 combination tail & stop & rear driving lights,
- › 4 direction indicators with hazard switch.
- › Orange strobe light on the cab.

and:

- › 2 Wide-beam work lights on the Hyster ECH spreader.

### Instruments/accessories

- › Warning lights: engine oil pressure, transmission oil pressure, transmission oil temperature, battery discharge indicator, low brake oil pressure, parking brake on.
- › Gauges: engine coolant temperature, fuel, transmission oil temperature, voltmeter, engine oil pressure.

Other indicators: hour meter, low brake pressure buzzer, combination key-type ignition/starter switch with starter lock out, reverse warning alarm.

## Ease Of Servicing

- › The hydraulic oil tank features a gauge for oil level as well as magnetic drain plugs.
- › The rearwards tilting cab is electrically powered.
- › In combination with a forward opening spring-assisted engine hood and two quickly removable (lightweight polyester) covers over the hydraulics, this provides truly excellent access for service work.





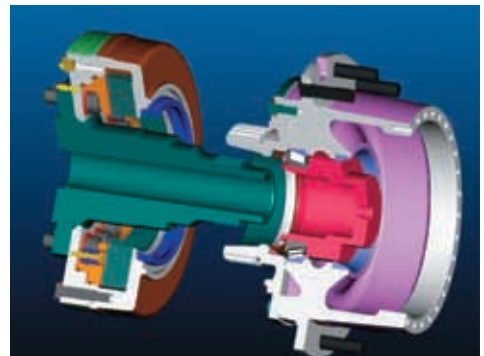

## Standard Equipment Highlights

- › Tyres 14.00 x 24, Bias ply (diagonal) pneumatics. Wide drive axle 4.12 m overall width.
- › Oil-immersed (wet) disc brakes.
- › Tropical cooling (of powertrain and hydraulic system) for up to 50° C. ambient.
- › Tier 3 emissions-certified engine. Engine and transmission protection systems. Aluminized steel anti-corrosive exhaust system
- › Autoshift transmission, also with forward-reverse shifting protection.
- › Air conditioning in the cab (with manual temperature control), joystick for intuitive control of mast and spreader functions, full-suspension seat with a height-adjustable backrest, reading light, top and rear sunscreens, two inside mirrors, two mirrors outside.
- › Rearwards tilting cab for service access.
- › Hyster ultra-wide 'Vista' lift mast with '1 to 4' lift ratio (see page 15). High mounted tilt cylinders.
- › Hydraulic accumulator in the hoist system, acting as load shock absorber.
- › EC spreader with 'reefer correction' function, by +/- 600 mm side shift.

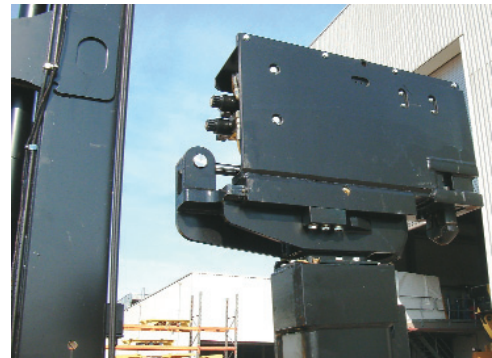

## Optional Equipment

- › **Extra power** package for H16.00-18.00XM-12EC  
Single container handlers only:  
172 kW / 230 Hp engine & TE-17 transmission,  
instead of standard 145 kW / 197 Hp engine & TE-13.
  - › **Tyres** 14.00 x 24: **Radial** pneumatics, or (Pneumatic Shaped) **Solids**.
  - › **Spare wheel** (complete tyre and rim).
  - › **Automatic greasing** system.
  - › **Mud flaps** on the rear fenders.
  - › **Wheel nut protection** rings, on the steer wheels.
  - › **Special colour(s)** RAL paint.
  - › **Storage box** (for container locks) on the running board, right-hand side.
  - › **Engine pre-heater** (electric, 220V).
- In-Cab / Operator convenience items:**
- › **Without air conditioning**, but including top and rear sun screens.
  - › **Air suspended seat**, instead of mechanically suspended seat.
  - › **Trainer seat** (small extra seat cushion).
  - › **Support stand** with mounting plate, to fit computer terminal or communication equipment.
  - › **Converter:** 24 Volt DC to 12 Volt DC.
  - › **H.I.D.** ('High Intensity Discharge' xenon) **work lights**, (4 x on the cab and 1 x on the rear of the cab), instead of standard Halogen lights.
- On the ECH spreader:**
- › **Four types of container engagement systems.**  
See Spreader characteristics.
  - › **30' Stop** (electro-hydraulic) of the telescopic movement.
  - › **Powered Pile Slope'** (PPS) function.  
For full details see Spreader characteristics.
  - › Only for 'Vertical Twistlocks': Spreader heads with hydraulic forward **Reach / Retract** function. To also handle some approx. 2.45-2.60 m wide "CPC" (Cellular **Pallet-wide Containers**).









## Strong Partners, Tough Trucks, for Demanding Operations, Everywhere.

Hyster supplies a complete range of warehouse equipment, IC and electric counterbalanced trucks, container handlers and reach stackers.

Hyster is committed to being much more than a lift truck supplier. Our aim is to offer a complete partnership capable of responding to the full spectrum of materials handling issues:

Whether you need professional consultancy on your fleet management, fully qualified service support, or reliable parts supply, you can depend on Hyster.

Our network of highly trained dealers provides expert, responsive local support. They can offer cost-effective finance packages and introduce effectively managed maintenance programmes to ensure that you get the best possible value. Our business is dealing with your materials handling needs so you can focus on the success of your business today and in the future.



Hyster Europe, Flagship House, Reading Road North, Fleet, Hants GU51 4WD, England.

Tel: +44 (0) 1252 810261

Fax: +44 (0) 1252 770702

Email: [info@hyster.co.uk](mailto:info@hyster.co.uk)

<http://www.hyster.co.uk>

A division of NACCO Materials Handling Limited.

Hyster®, **HYSTER**®, & Monotrol® are registered trademarks of Hyster Company in certain countries.

Fortens™, Pacesetter VSM™, DuraMatch™, DuraMatch Plus™, TouchPoint™, TouchControl™, EZXchange™, HSM™ & Vista™ are trademarks of Hyster Company in the United States and in certain countries where rights in unregistered trademarks are recognised.

