

REACHSTACKERS 42 – 45 TONNES.
TECHNICAL INFORMATION
KALMAR CONTAINER HANDLER, DRF.



FLEXIBLE CONTAINER HANDLING.

Reachstackers from Kalmar combine performance, comfort and reliability.

Container handling with a reachstacker is one of the most flexible handling solutions whether to operate a smaller one-unit terminal or a medium sized port. A reachstacker can handle loaded containers quickly and efficiently in narrow spaces, while still ensuring the driver has optimum visibility.

The extensive freedom allowed by the lifting equipment, boom and attachment, and its rotation possibilities, gives that the driver can improve the work efficiency of the unit, by not needing to approach the container from a 90 degrees position.

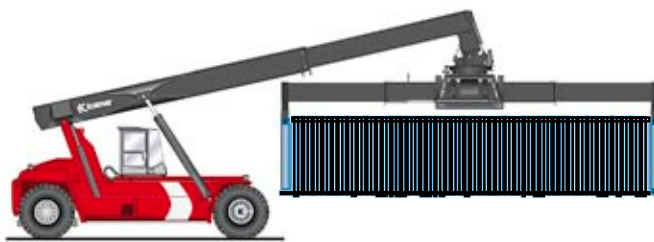

Containers can be lifted lengthwise making it possible to deliver the container into and through workshop doors, port shed gates, etc in then low, longitudinal position.

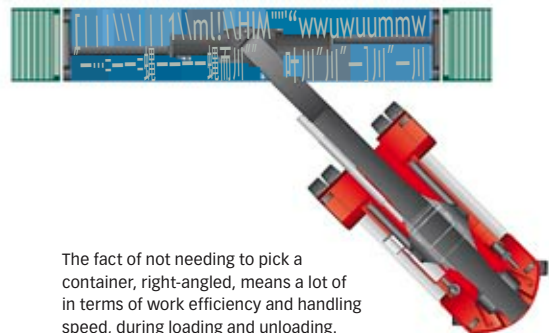

The fact of not needing to pick a container, right-angled, means a lot of in terms of work efficiency and handling speed, during loading and unloading.

Instead, the container can be picked or dropped-off by the unit approaching from any angle <90 degree. And by rotating the spreader and reaching the boom to suitable length, the driver can handle the container from any position. As an additional advantage, the aisle width – driving space depth, needed – can be squeezed, as well.

Wear on the machine and the working surface can be reduced if the reachstacker is used in the right way. Compared to a conventional forklift, a larger proportion of the lifting manoeuvre can be performed while the unit is stationary.

Containers can also be lifted and transported lengthwise, making it possible to deliver the container into and through workshop doors, port shed gates, etc in then low, longitudinal position. This can be a vital ability for the possibility of container stripping and stuffing inside the sheds.

The goals in developing a reachstacker are clear: high performance throughout the operating cycle, high user-friendliness, and low running costs. Together with a high level of environmental awareness, this has resulted in new technical solutions and systems.

Any driver with the ability to take advantage of the machine's capacity and technical benefits will find this reachstacker a powerful, flexible tool for handling containers with the lowest possible operating and maintenance costs.

The technical information in this material primarily refers to the DRF. Specific information about the DRD's technical systems is available on request.

MODEL DESIGNATION

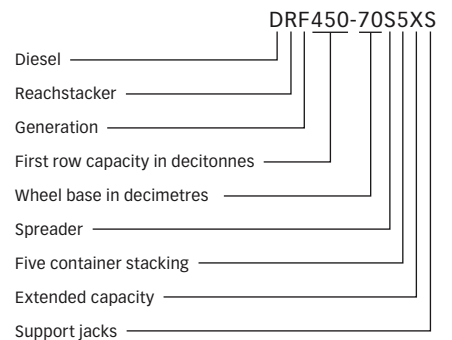

MAXIMUM LIFTING CAPACITY IN CONFINED SPACES.

The chassis and lifting equipment have been developed to ensure the best possible performance, strength and user-friendliness. The nature of the working environment and capacity requirements at different load centres determine which model is the most suitable.

LIFTING BOOM

The lifting boom carries the load. The design has been optimised using computer simulations and extensive field tests. The powerful execution in high-tensile steel has a minimal number of welds for maximum strength. The boom's fixture in the frame and the lifting cylinders are fitted with spherical plane thrust bearings. The width of the rear fixture (boom suspension) increases the overall rigidity and the good rearward visibility.

The boom has two sections, the inner and outer boom. The sliding plates between the inner and outer boom require no lubrication. The cable-chain which leads hydraulic hoses and cabling to the attachment is made of maintenance-free plastic.

LIFTING BOOM HYDRAULICS

Oil is fed to the boom functions by load sensing pumps. To reduce pressure drops, wide hydraulic hoses have been used for the boom functions. A wider hose produces a lower flow rate with the same volume, thereby reducing friction and heat development. The blocking valves on the lifting and extension cylinders block the oil flow when the boom functions are not in use, which secures the boom position. The base of

the lifting cylinders has a new design that produces smooth stopping and starting movements.

The boom's lifting and extension function is damped in the end positions for reduced wear and greater comfort.

ROTATOR

The rotator is fixed in the inner boom and enables the container to be rotated. The rotator consists of an upper and a lower yoke joined with a powerful bearing. Rotation is enabled by two hydraulic motors, which drive a gear-ring. Two hydraulic dampers help prevent the container from swinging lengthwise.

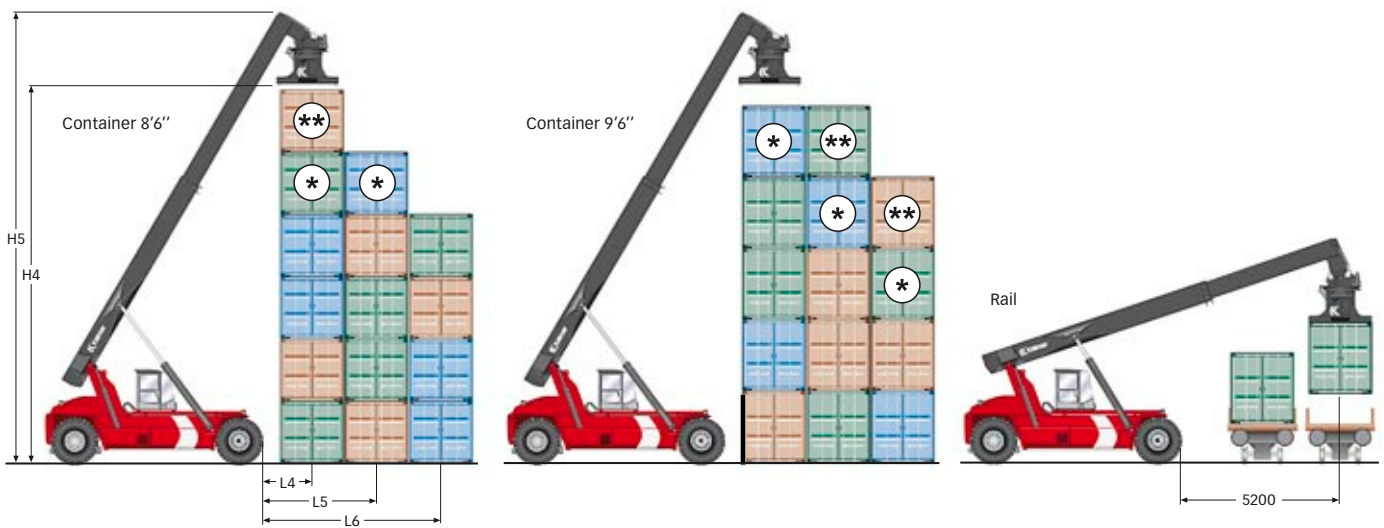

CAPACITY	Container 8'6"			Container 9'6"			Rail	Lifting height		Load centre		
	1:st row	2:nd row	3:rd row	1:st row	2:nd row	3:rd row	2:nd row	H4 (mm)	H5 (mm)	L4 (mm)	L5 (mm)	L6 (mm)
DRF420-60S5	41*/42	25*	11	40*/42	25*	11*	16	15100	18100	1965	3815	6315
DRF450-60S5	43*/45	27*	13	42*/45	27*	13*	18	15100	18100	1965	3815	6315
DRF450-60S5M	43*/45	30*	15	42*/45	30*	15*	19	15100	18100	1965	3815	6315
DRF450-60S5X	43*/45	35*	18	42*/45	35*	18*	24	15200	18200	1865	3815	6315
DRF420-65S5	41*/42	28*	14	40*/42	28*	14*	18	15100	18100	1965	3815	6315
DRF450-65S5	43*/45	31*	16	42*/45	31*	16*	20	15100	18100	1965	3815	6315
DRF450-65S6	42**/44*/45	31*	16	43*/45	31**	16**	20	16200	19250	1965	3815	6315
DRF450-65S5X	45*	36*/38	21	43*/45	37*/38	21*	27	15200	18200	1865	3815	6315
DRF450-65S6X	43*/45*	35*/38	21	43*/45	34**/36*/38	21**	27	16300	19350	1865	3815	6315
DRF450-70S5	42**/45	34*	18	42*/45	34*	18*	23	15100	18100	1965	3815	6315
DRF450-70S5X	45*	39*/41	23	45*	40*/41	23*	29	15100	18200	1865	3815	6315
DRF450-70S5XS	45*	39*/41	23	45*	40*/41	23*	29	15100	18200	1865	3815	6315
DRF450-70S5XS (SJD)	45*	39*/41	31	45*	40*/41	31*	35	15100	18200	1865	3815	6315
DRF450-75S5XS	45*	43*/45	26	45	45*	26*	32	15200	18400	1865	3815	6315
DRF450-75S5XS (SJD)	45*	43*/45	34	45	45*	34*	41	15200	18400	1865	3815	6315

(SJD) = Support jacks down
 For more detailed information please advice the technical Data Sheet

ATTACHMENT

The primary function of the attachment is to firmly attach the container during lifting. This is done with four twistlocks which rotate, thereby securely gripping the container’s corner fittings.

The mechanical levelling ensures that the twistlocks reach the corners, even if the container is leaning.

The attachment can easily be adapted to different container standards. A hydraulic motor drives the function via chains. The container can also be moved sideways to facilitate loading and unloading, or to compensate for unbalanced loads. Two hydraulic cylinders perform the side-shift movement.

ATTACHMENT AND ROTATOR HYDRAULICS

The functions are fed with a constant pressure, which means there is no pumping of hydraulic oil when the functions are not in use. One valve serves all the hydraulic functions in the attachment. The valve ensures that each hydraulic function is fed the exact amount of oil needed to optimise the speed of the functions’ movements. The attachment functions are damped in the end positions.

CHASSIS

The frame forms the basis of the machine’s lifting and manoeuvring characteristics. The frame’s beam construction, along with its width, makes the reachstacker stable, torsion resistant and service-friendly.

Firstly, a large number of computer simulations have been run in order to eliminate critical tensions under various kinds of strain. The simulations were characterised by uncompromising demands on the fundamental principles of stability, manoeuvrability and visibility. Secondly, the machine has then undergone extensive field-testing to fully ensure its dynamic strength.

The reachstacker is available with a variety of wheelbases to fulfil demands on lifting capacity in relation to manoeuvrability and operating economy in the best way.

INCREASED CAPACITY

In some cases, high capacity requirements in the second and third rows of containers, or on the far rail track, call for the benefit of support legs. In other cases, it may be the restricted handling space that determines the most suitable model.

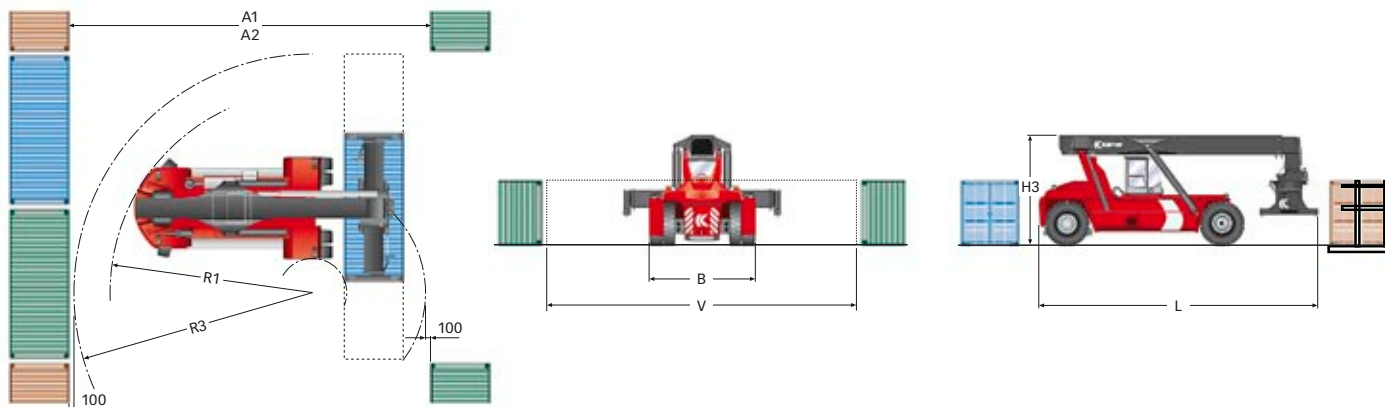

DIMENSIONS	Aisle width (mm)		Turning radius (mm)		Main dimensions (mm)						Service weight (kg)
	A1 - 20 ft	A2 - 40 ft	R1 - 20 ft	R3 - 40 ft	B	V	L	H3	Clearance	Wheels	
DRF420-60S5	11200	13600	8100	9400	4150	6055-12185	11200	4500	250	18.00x25/36	65500
DRF450-60S5	11200	13600	8100	9400	4150	6055-12185	11200	4500	250	18.00x25/40	67400
DRF450-60S5M	11200	13600	8100	9400	4150	6055-12185	11200	4500	250	18.00x25/40	69400
DRF450-60S5X	11200	13600	8100	9400	4150	6055-12185	11200	4600	300	18.00x33/36	77400
DRF420-65S5	11600	13600	8500	9400	4150	6055-12185	11700	4500	250	18.00x25/36	66500
DRF450-65S5	11600	13600	8500	9400	4150	6055-12185	11700	4500	250	18.00x25/40	69000
DRF450-65S6	11900	13900	8500	9450	4150	6055-12185	12000	4500	250	18.00x25/40	69800
DRF450-65S5X	11600	13600	8500	9400	4150	6055-12185	11700	4600	300	18.00x33/36	76300
DRF450-65S6X	11900	13900	8500	9450	4150	6055-12185	12000	4600	300	18.00x33/36	77500
DRF450-70S5	12000	13600	8900	9400	4150	6055-12185	12200	4500	250	18.00x25/40	69400
DRF450-70S5X	12100	13600	9000	9400	4150	6055-12185	12200	4700	300	18.00x33/36	77800
DRF450-70S5XS	12100	13600	9000	9400	4150	6055-12185	12200	4700	300	18.00x33/36	79300
DRF450-75S5XS	12500	13600	9400	9400	4150	6055-12185	12700	4750	300	18.00x33/36	82100

NO MACHINE IS BETTER THAN ITS DRIVER.

Kalmar's goal while developing the cabin has been to assure the driver the best conceivable safety, ergonomics and visibility.

SOUND AND VIBRATION

The cabin is separately suspended and isolated from the frame with powerful rubber dampers. Effective shock absorption minimises vibration. The cabin is fitted with insulation material both inside and out. The maximum noise level inside the cabin is 72 dB (A) measured according to DIN45635.

ERGONOMICS

Controls and instruments are intuitively positioned and work the way a driver would expect. Search lights in the buttons and switches make them easy to identify and use, even in darkness.

In the centre above the steering wheel is a display showing operating information, warning messages, error codes etc. To the left of the display is the panel for warning and indication lamps.

The driver's seat and control lever for the lifting functions can be adjusted to the optimum individual driving position.

The pedals are designed for high comfort, with a hanging accelerator. The internal dimensions are otherwise generous, offering an open floor space.

CLIMATE

An electronic controlled heating and ventilation system comes as standard, as do filters for fresh air and recirculation. An air cooling system comes as a standard. The cooling system provides a good cooling effect, even in extremely high temperatures. A pollen filter is available as an optional extra.

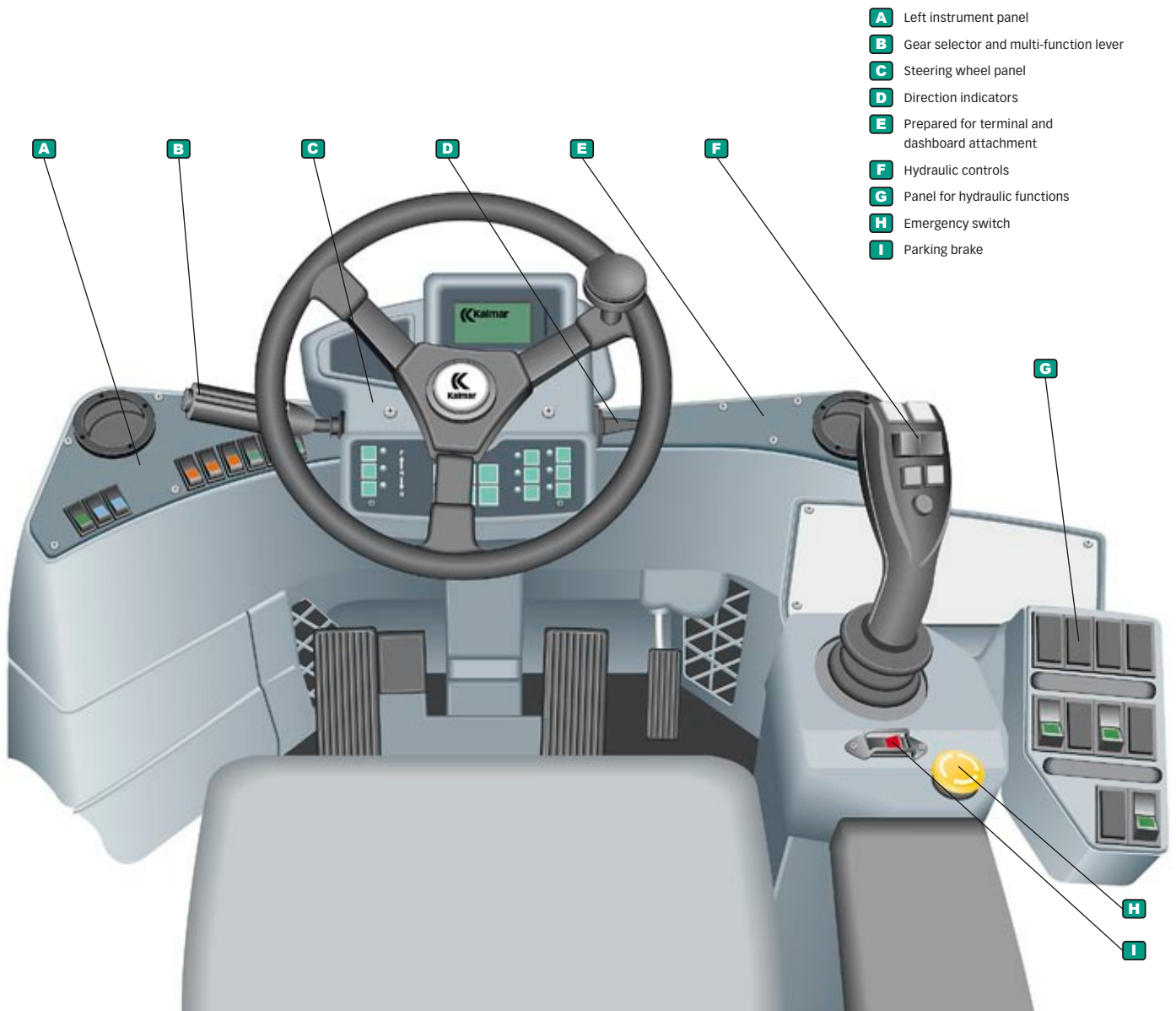

- A** Left instrument panel
- B** Gear selector and multi-function lever
- C** Steering wheel panel
- D** Direction indicators
- E** Prepared for terminal and dashboard attachment
- F** Hydraulic controls
- G** Panel for hydraulic functions
- H** Emergency switch
- I** Parking brake

PERFORMANCE IS THE RESULT OF HOW WELL THE MACHINE'S FUNCTIONS WORK TOGETHER.

The efficacy of the lifting equipment is determined by a combination of lifting speed, capacity, visibility and user-friendliness. Lifting places heavy demands on the engine and working hydraulics, but lifting is only part of the operating cycle. Before the machine is in position to load or unload, the demands are instead on precise control with tight turning radius, effective brakes and high pulling power. And of course, all the functions must still perform optimally even after heavy use.



TRANSMISSION

The transmission transfers power from the engine to the hydraulic pumps and drive line. The engine and gearbox control systems work together to find the optimum balance between power and fuel economy at any given point.

The transmission system consists of a torque converter and a gearbox. The same gearbox is used whichever engine is chosen. The gearbox is automatic, but can partly be shifted manually. The torque converter is a hydraulic coupling positioned between the engine and gearbox. The gearbox and torque converter work together via a joint hydraulic system.

BRAKES

The brake circuit is separated from the hydraulic system and has its own tank, cooler and high-pressure filter. A temperature transmitter in the separate tank regulates the cooler fan.

The foot-brake valve, which controls the oil feed to the brakes, is sensitive enough so that the driver can brake optimally yet still gently. The parking brake is activated automatically when the ignition is turned off.

DRIVE LINE

The propeller shaft and drive axle transfer the power from the transmission to the driving wheels. The mountings on the propeller shaft are fitted with cross-flanges for optimum strength.

The drive axle shifts gear down in two stages, differential and hub reduction. The engine only achieves maximum torque at the drive wheels, which spares the transmission.

Standard drive train

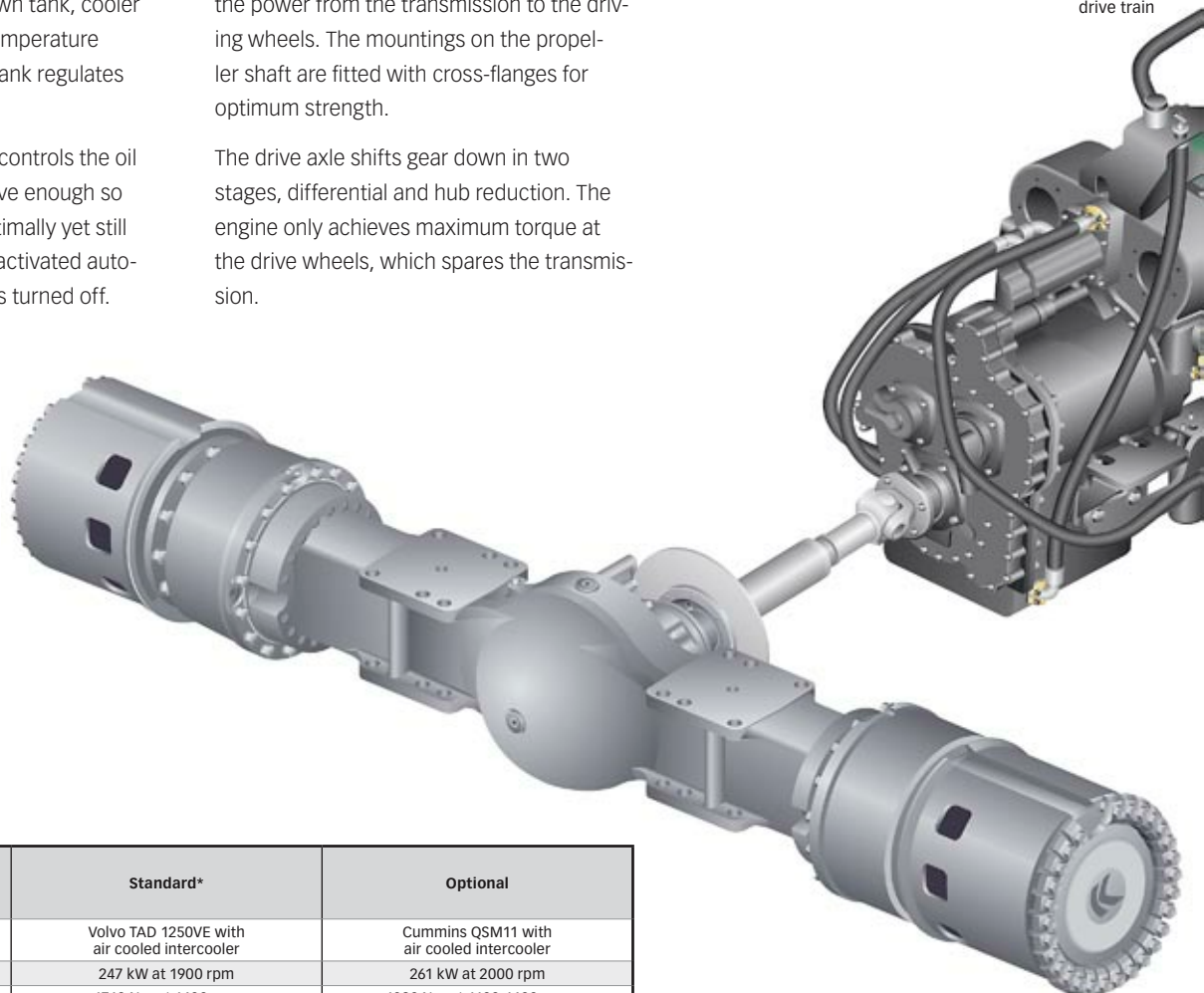

DRIVE TRAIN		Standard*	Optional
Engine	Manufacturer Model	Volvo TAD 1250VE with air cooled intercooler	Cummins QSM11 with air cooled intercooler
	Power	247 kW at 1900 rpm	261 kW at 2000 rpm
	Peak torque	1760 Nm at 1400 rpm	1830 Nm at 1100-1400 rpm
Transmission		Dana – 15.7TE32418	Dana – 15.7TE32418
Driving axle		Kalmar WDB	Kalmar WDB

* Stage 2 and Tier 2 outside US and EU

ENGINE

A Volvo engine is standard. Cummins is available as optional extra. The engine provides power for driving and the working hydraulics. The engines are low-emission turbo diesels with unit injectors and intercoolers.

The design of the combustion vessels, along with the precise fuel injection control, ensures more efficient combustion. Emissions decrease, while power and torque increase. The engines fulfil the requirements of 97/68*2004/26 EC stage 3, US EPA Tier 3.

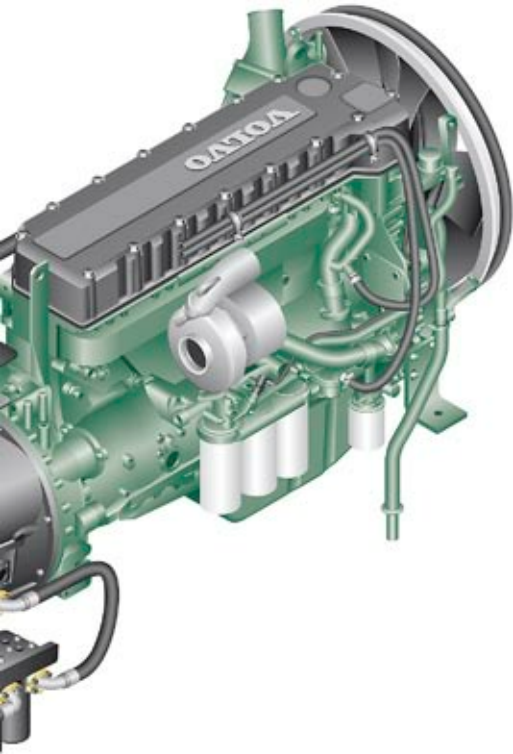

The engine and transmission cooler is a single unit that uses the same fan. The engine cooler's separate expansion vessels are fitted with a level transmitter that indicates low coolant level.

When the engine temperature is too high or the coolant level or oil pressure too low, the engine's power output is actively reduced. Should the oil pressure fall below a certain level, the fuel feed to the engine is cut off automatically.



Cummins QSM11 with air cooled intercooler can be fitted as optional extra.

STEERING SYSTEM

The steering axle has been cut from a single piece of robust steel, which means as few maintenance-requiring parts as possible and high structural strength.

The hydraulics that feed oil to the steering cylinder is optimised for enhanced driving sensation. Orbitrol and the priority valve jointly provide gentle yet precise steering movements.

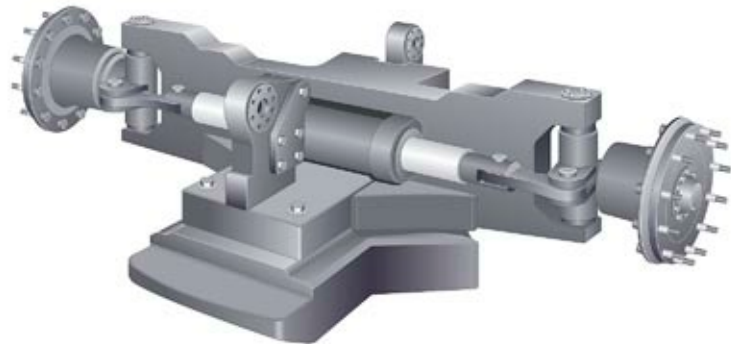

The new steering axle has few maintenance-requiring parts and high structural strength.

PERFORMANCE	Lifting speed (m/s)		Lowering speed (m/s)		Driving speed (km/h)		Gradeability (%)			Draw pull (kN)
	unloaded	at 70% of rated load	unloaded	at rated load	unloaded (F/R)	at rated load (F/R)	at 2 km/h, unloaded	at 2 km/h, at rated load	max, unloaded	max
DRF420-60S5	0,42	0,25	0,36	0,36	25/25	21/21	37	22	40	370
DRF450-60S5	0,42	0,25	0,36	0,36	25/25	21/21	37	22	40	370
DRF450-60S5M	0,42	0,25	0,36	0,36	25/25	21/21	37	22	40	370
DRF450-60S5X	0,42	0,25	0,36	0,36	27/27	21/21	28	18	40	320
DRF420-65S5	0,42	0,25	0,36	0,36	25/25	21/21	37	22	40	370
DRF450-65S5	0,42	0,25	0,36	0,36	25/25	21/21	37	22	40	370
DRF450-65S6	0,42	0,25	0,36	0,36	25/25	21/21	37	22	40	370
DRF450-65S5X	0,42	0,25	0,36	0,36	27/27	21/21	28	18	40	320
DRF450-65S6X	0,42	0,25	0,36	0,36	27/27	21/21	28	18	40	320
DRF450-70S5	0,42	0,25	0,36	0,36	25/25	21/21	37	22	40	370
DRF450-70S5X	0,42	0,25	0,35	0,35	26/26	20/20	27	17	39	320
DRF450-70S5XS	0,42	0,25	0,35	0,35	26/26	20/20	27	17	39	320
DRF450-75S5XS	0,41	0,24	0,35	0,35	25/25	19/19	25	15	35	320

THE DISTRIBUTED AND REDUNDANT CONTROL SYSTEM.

For the reachstacker to work perfectly a robust communication network is needed, along with a system that gives the functions power.

Two things are needed for a command initiated by the driver to result in a particular function, or for several functions to work together: power-feed and communication.

The power-feed supplies the machine's electrical and electrohydraulic functions with voltage, while the communication system controls and checks that the functions have been activated, waits in standby mode or indicates a fault.

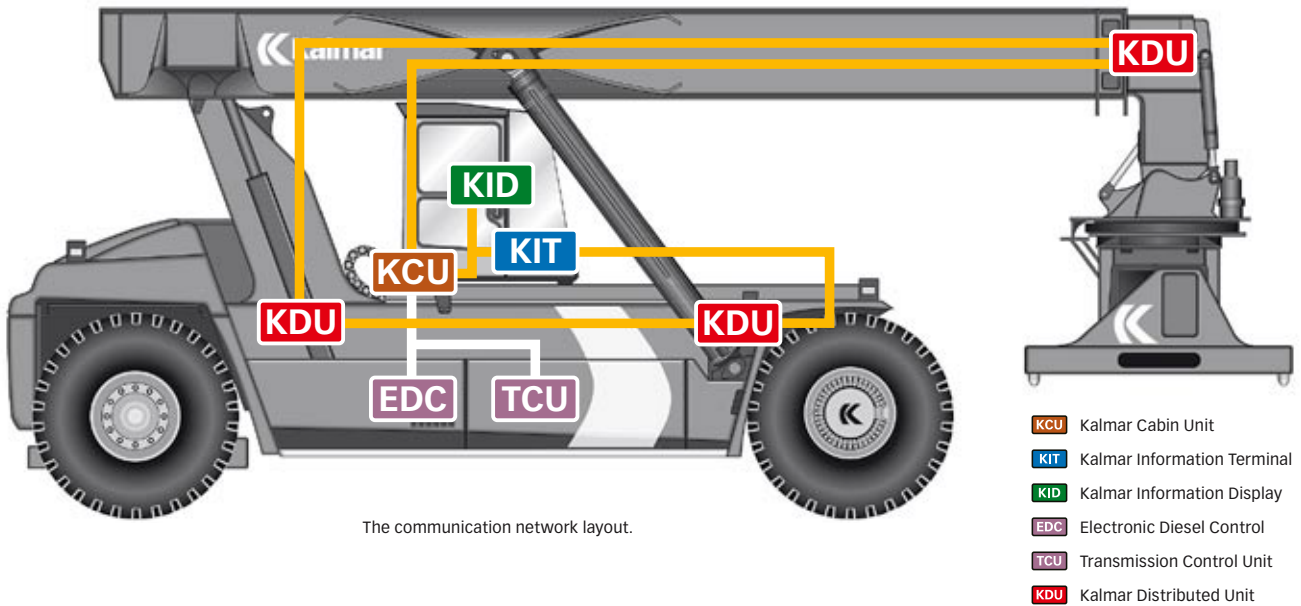

COMMUNICATION

The distributed power-feed and communication network consists of electrical components and a microcomputer-based system for controlling and monitoring the reachstacker's functions.

The most important components in the network are the control units (nodes). They distribute control of the machine's functions. Each node has its own processor. The nodes integrate with each other and all communication; control signals and signal information are sent via data buses.

The nodes transmit their signals in messages on the network. Each message contains several signals and has its own address. Any units that need to know the status of a signal listen out for the address of the signal's message. All the nodes in the network listen to each other.

CAN-bus is a two-wire transfer of data and a definition of a bus type. CAN-bus technology has been chosen because it provides a reli-

able, robust transfer of data and is difficult to disrupt. CAN-bus loops have been used in Kalmar machines since 1995.

The greatest benefit of using CAN-bus technology is that the amount of cabling can be reduced. All that is needed to establish communication are two data-bearing leads and two leads for feeding the nodes' processors. The network loop for both the CAN-bus and the nodes' processor feed are redundant.

The Kalmar Cabin Unit (KCU) is the control node for the entire network. There are several nodes, called KDUs (Kalmar Distributed Units), in the network. Each node is positioned near to the functions it is designed to deal with. With certain optional equipment, further nodes (KDUs) are connected to the existing network near to where the specific functions are located.

The Transmission Control Unit (TCU), which is the gearbox node, deals with the gearbox.

The unit is connected in a separate CAN-bus loop with the EDC engine node (Engine Diesel Control) and KCU. The engine node controls the fuel injection and receives its control signals from its own transmitters on the engine.

POWER SUPPLY

Power-feed for the functions differ from the feed required for communication and feeding of the nodes' processors.

Each distribution unit (node) in the distributed network is fed voltage from one of the power distribution boxes. The distribution boxes are located inside the cabin and on one side of the frame. The distribution units (nodes) guide power from the distribution box to the required functions based on the instructions in the messages from the communication network.

CONTROL FUNCTIONS

The driver and machine communicate via the Kalmar Information Terminal (KIT) and the Kalmar Information Display (KID). Control signals initiated by the driver are transferred to the KCU, which handles all incoming signals from the controls in the cabin, and sends messages out into the communication network.

The system also distributes information to the driver such as alarm warnings, operating details and action-guided information. In these cases, messages are sent from one of the nodes in the network, captured by the KCU, and then presented in the KID or the panel for warning and indication lamps. The KID shows information from the control units in the form of messages, status, fault indication etc.

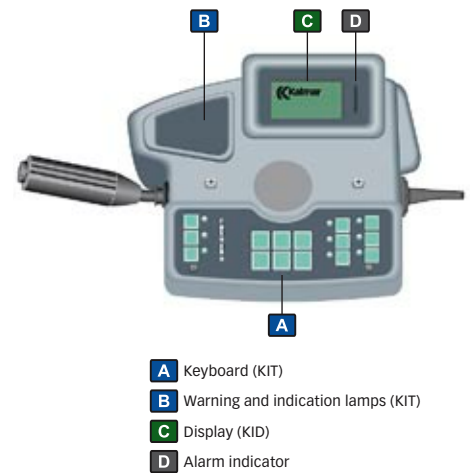

RELIABILITY

High reliability is achieved by reducing the number of components and ensuring each individual component maintains a consistent high quality.

One of our guiding principles in designing the reachstacker was to minimise the number of potential sources of error. Therefore, the machine consists of as few components and moving parts as possible. The functionality and operational reliability of each component is assured by extensive testing.



THE MACHINE'S STRUCTURE

Kalmar has been making reachstackers since the mid-1980s. There are a lot of Kalmar machines around the world, used in all kinds of climates. Overall, this has helped build our completely unique experience of this machine type. The machine's lifting equipment, frame and structure has been fine-tuned over the years, and today we can offer the best balance of performance and operational reliability in the machine's mechanical components and structure.

HYDRAULIC COMPONENTS AND COUPLINGS

The number of hydraulic components and hydraulic couplings has been minimised. The main valve has an integrated servo, which helps increase control of the oil flow

and keep the number of components to a minimum.

The boom's lifting and extension cylinders are fitted with double gaskets. Moreover, the machine is fitted with extremely reliable, well-sealed ORFS (O-Ring Face Seal) couplings in all the hydraulic hoses as standard.

TEMPERATURE CONTROL AND HYDRAULIC CLEANLINESS

In order to maintain optimum functionality in the hydraulic system even under extreme operating conditions, cleaning and cooling of the hydraulic oil is highly efficient. The brake circuit is separated from the rest of the hydraulic system and is fitted with its own cleaning process and cooling system.

REDUNDANT COMMUNICATION NETWORK

A network of distributed control units (nodes) using limited cabling and fewer couplings, meaning fewer sources of error.

The power-feed for each node is independent of the other nodes, which help prevent other nodes from being disrupted, should one stop working. The same applies to the transfer of control signals. Both the power-feed and control signal transfer are redundant, so that power or signals always have two paths to choose for maintaining communication, thus offering extra safety and reliability.

SERVICE FRIENDLY.

Few, short stoppages for service and maintenance minimise loss of production time.

In the longer term, the reachstacker's reliability is a crucial parameter in the overall handling economy. At the same time, each machine must be service-friendly so it can be maintained and repaired quickly and easily, thereby maintaining high reliability.

Kalmar's products have always been very service friendly as we continuously strive:

- to minimise the number of components
- to choose the highest quality components throughout
- to use lubrication-free options wherever possible
- to optimise accessibility for service and maintenance

SERVICE ACCESSIBILITY

The top covers on the frame can be removed quickly and easily. Most of the main components are easily accessible from above in the broad frame when inspection and maintenance need to be carried out. The cabin can also be moved lengthwise thus further increasing ease of access.



High availability and grouped service points makes daily inspections and maintenance work easy.

FAULT IDENTIFICATION

The control and monitoring system offers completely new opportunities for fault identification. There are over 400 fault codes and 140 diagnostics menus built into the system.

The overall aim is to make stoppages as few and as short as possible. With this machine, Kalmar has created the best possible balance between performance and operating economy – in other words, a low cost over the entire life cycle of the reachstacker.

FOUR REASONS TO CHOOSE KALMAR.

1 / COST OVER LIFETIME

Kalmar offers the best cost over lifetime for its customers. Modern and innovative technology together with lasting equipment and comprehensive service ensures Kalmar increases its customers' productivity. Every day.



2 / GLOBAL NETWORK

Kalmar invests in its sales and service network. Thus Kalmar is a reliable and trustworthy supplier with ability to serve demanding customers.



3 / LOCAL SERVICE

Kalmar practises innovative service development. Because of Kalmar's local customer service strategy, Kalmar knows its customers' local conditions, and can provide efficient and effective service in every location.

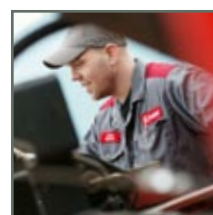

4 / CONTINUOUS DEVELOPMENT

Kalmar has not stopped at the top, but continuously improves its offering. New services as well as investments in automation and environmentally friendly solutions work for our customers benefit.

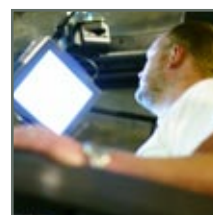

Kalmar Industries AB

Torggatan 3, SE-340 10 Lidhult, Sweden
tel. +46 372 260 10, fax. +46 372 263 93

