

Kalmar DCF70-100, E4-E8

Empty container handlers 7 – 10 tonnes



The result of a technical evolution

Kalmar machines especially adapted to handle empty containers have been developed for a long time. Now we have brought our empty container handlers in to the new generation, the Kalmar F series – the technical platform that represents a major technical revolution in container handling.

The DCF70-100 is a high quality machine that allows you to move as many units as possible in the shortest amount of time in the most profitable way. In order to get the optimum balance of economy, lifting height and performance for each client, Cargotec offers a wide range of empty container handlers.

As for all Kalmar F series machines safety is a key factor. The DCF70-100 can provide the best everyday performance and at the same time reassure the safety of the personnel. The components are well known and are often found in other Kalmar machines and have therefore been tested through an extended time and can provide the highest possible reliability.

Efficient and reliable

The design of the chassis, mast and spreader has resulted in a machine with very good dimensional, stability and operational characteristics. These combined allow the operator to focus on the task instead of the management of the machine.

Additionally, we have ensured that every single detail, component and system have been selected and manufactured to provide the highest possible reliability. When we deliver the machine we want to make sure that all aspects are factored in. Once produced all machines go through an extensive testing programme before they leave the factory in order to secure a high level of reliability.

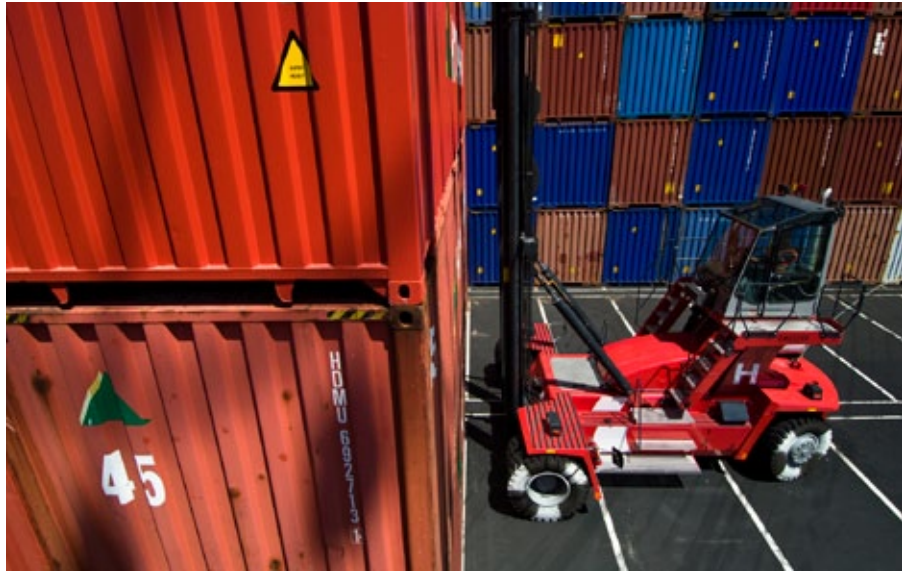

Dimensions		DCF70-40	
		E4	E5
Lifting capacity	Rated (kg)	7000	7000
	Load centre (mm)	L4	1220
	Number of containers, 8'6" container	4	5
	Number of containers, 9'6" container	4	5
Truck	Truck length (mm)	L	6400
	Truck width (mm)	B	3400
	Height, basic machine (mm)	H6	3900
	Seat height (mm)	H8	2700
	Distance between centre of front axle – front of attachment (mm)	L2	1190
	Wheelbase (mm)	L3	4050
	Track (c-c) front – rear (mm)	S	2750-2210
	Turning radius, outer – inner (mm)	R1 – R2	5400 – 285
	Ground clearance, min. (mm)		230
	Min. aisle width for 90° stacking, 20' container (mm)	A1	10000
Min. aisle width for 90° stacking, 40' container (mm)	A2	14000	
Standard duplex mast	Lifting height (mm)	H4	12100
	Mast height, min. (mm)	H3	7105
	Mast height, max (mm)	H5	12100
	Mast tilting, forward – backward (mm)	α – β	3 – 3
Attachment	Ground clearance, min. (mm)		–
	Width (mm)	b	6065 – 12200
	Height under twistlock (mm)	H10	2180
	Height under hooks (mm)	H10	–
Weight	Sideshift ± (mm)	V1	600
	Service weight (kg)		32500
	Axle load front, unloaded (kg)		21300
	Axle load front, at rated load (kg)		32500
	Axle load back, unloaded (kg)		11200
Wheels / tyres	Axle load back, at rated load (kg)		7000
	Type, front – rear		Pneumatic
	Dimensions, front – rear (inch)		12.00×20 – 12.00×20
	Number of wheels, front – rear (*driven)		4* – 2
Steering system	Pressure (Mpa)		1,0
	Type – manoeuvring		Servo assisted – Steering wheel
Service brake system	Type – affected wheels		Wet disc brakes – Drive wheel
	Type – affected wheels		Spring brake – Drive wheel
Hydraulic pressure	Max. (Mpa)		21,0
	Hydraulic fluid volume (l)		230
Fuel volume	Fuel volume (l)		280
	AdBlue volume (l)		–

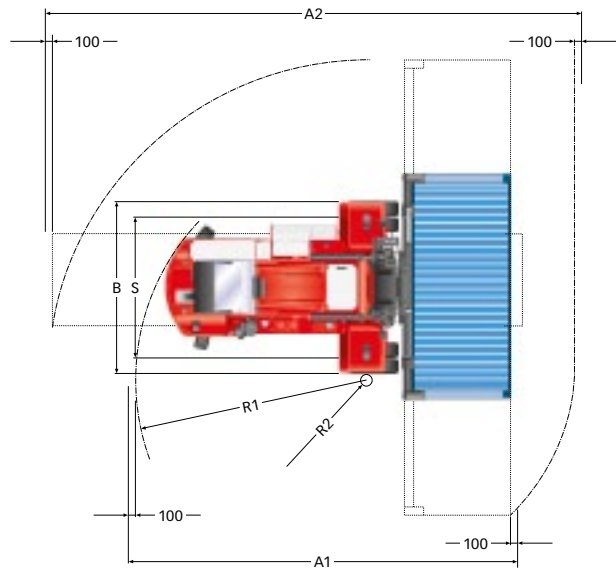
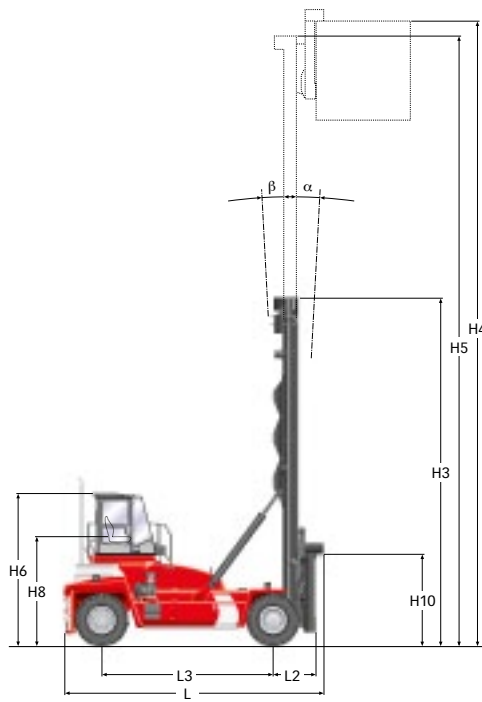

DCF80-45				DCF90-45				DCF100-45			
E5	E6	E7	E8	E5	E6	E7	E8	E5	E6	E7	E8
8000	8000	8000	8000	9000	9000	9000	9000	10000	10000	10000	10000
1220	1220	1220	1220	1220	1220	1220	1220	1220	1220	1220	1220
5	6	7	8	5	6	7	8	5+1	6+1	7+1	8+1
5	5	6	7	5	5	6	7	5+1	5+1	6+1	7+1
6900	6900	6900	6900	6900	6900	6900	6900	6900	6900	6900	6900
4000	4000	4000	4000	4000	4000	4000	4000	4500	4500	4500	4500
3940	3940	3940	3940	4000	4000	4000	4000	4000	4000	4000	4000
2800	2800	2800	2800	2900	2900	2900	2900	2900	2900	2900	2900
1170	1170	1170	1170	1170	1170	1170	1170	1240	1240	1240	1240
4550	4550	4550	4550	4550	4550	4550	4550	4550	4550	4550	4550
3270 – 2250	3270 – 2250	3270 – 2250	3270 – 2250	3270 – 2250	3270 – 2250	3270 – 2250	3270 – 2250	3750 – 2250	3750 – 2250	3750 – 2250	3750 – 2250
6000 – 2000	6000 – 2000	6000 – 2000	6000 – 2000	6000 – 2000	6000 – 2000	6000 – 2000	6000 – 2000	6200 – 2200	6200 – 2200	6200 – 2200	6200 – 2200
250	250	250	250	300	300	300	300	–	–	300	300
10000	10000	10000	10000	10000	10000	10000	10000	10000	10000	10000	10000
14000	14000	14000	14000	14000	14000	14000	14000	14000	14000	14000	14000
15180	16180	18680	21180	15240	16240	18740	21240	15300	16300	18800	21300
8540	9040	10290	11540	8600	9100	10350	11600	8600	9100	10350	11600
15040	16040	18540	21040	15100	16100	18600	21100	15100	16100	18600	21100
3 – 3	3 – 3	3 – 3	3 – 3	3 – 3	3 – 3	3 – 3	3 – 3	3 – 3	3 – 3	3 – 3	3 – 3
–	–	–	–	–	–	–	–	–	–	–	–
–	–	–	–	–	–	–	–	–	–	–	–
2180	2180	2180	2180	2240	2240	2240	2240	–	–	–	–
–	–	–	–	–	–	–	–	2300	2300	2300	2300
600	600	600	600	600	600	600	600	600	600	600	600
36450	37100	38725	40350	37300	37950	39575	41200	40100	40750	42375	44000
23900	24550	26175	27800	24100	24750	26375	28000	25600	26250	27875	29500
36050	36700	38325	39950	37700	38450	40075	41700	40800	41550	43175	44800
12550	12550	12550	12550	13200	13200	13200	13200	14500	14500	14500	14500
8400	8400	8400	8400	8500	8500	8500	8500	9200	9200	9200	9200
Pneumatic				Pneumatic				Pneumatic			
12.00x24 – 12.00x24				14.00x24 – 14.00x24				14.00x24 – 14.00x24			
4* – 2	4* – 2	4* – 2	4* – 2	4* – 2	4* – 2	4* – 2	4* – 2	4* – 2	4* – 2	4* – 2	4* – 2
1,0	1,0	1,0	1,0	1,0	1,0	1,0	1,0	1,0	1,0	1,0	1,0
Servo assisted – Steering wheel				Servo assisted – Steering wheel				Servo assisted – Steering wheel			
Wet disc brakes – Drive wheel				Wet disc brakes – Drive wheel				Wet disc brakes – Drive wheel			
Spring brake – Drive wheel				Spring brake – Drive wheel				Spring brake – Drive wheel			
19,0	19,0	19,0	19,0	20,0	20,0	20,0	20,0	22,5	22,5	22,5	22,5
320	320	320	320	320	320	320	320	320	320	320	320
380	380	380	380	380	380	380	380	380	380	380	380
15	15	15	15	15	15	15	15	15	15	15	15

Protective and safe with total control

The lifting equipment of Kalmar DCF is an integrated assembly consisting of mast, carriage, spreader, hydraulics and control system. This is to ensure you get a reliable and good running machine with high availability even after long shifts and high load stresses.

To leverage operational productivity it's essential that the driver has full control over every moment of the handling sequence. The open design of the mast optimises the visual contact with the stack, container corners, twistlock and spreader.

Lifting as much as 8+1 high puts high demands on sturdiness of the equipment. Stronger dimensions on the tilting cylinders and with the top section threaded into the cylinder creates a robust lifting equipment.

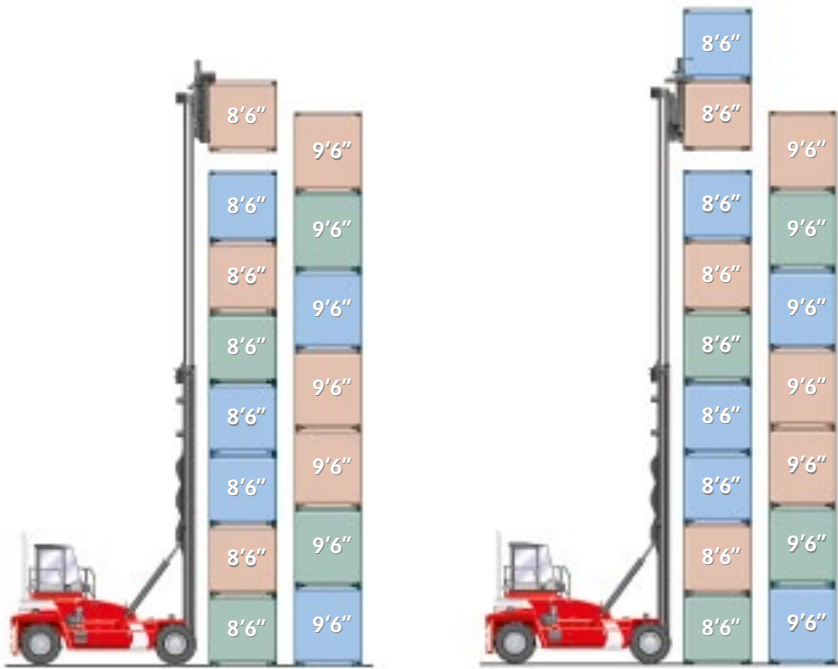

Single and double stacking

We have developed empty container handling concepts for both single- and double stacking for different lifting heights. Our DCF Empty range stretches from a capacity of 4 high up to 8+1 high. The decision on which concept is most suitable depends on individual operational demands.

The open design of the mast optimises the visual contact with the stack, container corners, twistlocks and spreader.

Single stacking with twistlocks

The single handling concept starts at 4 high stacking and up to 8 high. Characteristic for the machines dedicated for single stacking is flexibility, stability and high lifting speeds.

Twistlock attachments are widely used on many Kalmar machines over the globe.

High demands on selectivity and limitations in ground space are the key factors when considering single stacking equipment.

Double stacking with hooks

Double stacking of containers is an important step in increasing the productivity in the empty container handling business. Double stacking can be a very demanding application for the Empty Container Handler. The DCF100 model fulfils these high requirements of stability and strength with margin. Stacking two containers simultaneously is most of all a question of extreme demands of operational efficiency before demands on selectivity.

Mast

All machines in the DCF70-100 series are equipped with the sturdy profile, designed according to the free visibility principle. The mast profiles are made of high tensile steel, designed for minimal obstruction of the field of vision and for long service life with minimal deflection at high lifting heights.

The mast is made for high reliability and simple maintenance. It requires only two hoses and one cable passing over the mast roller to feed the hydraulic and electrical functions of the spreader.

Carriages

Three integrated carriages are available. Which one you choose is depending on your handling needs and which attachment you need. For single stacking the attachment is landing from above

(twistlocks) and a carriage with passive levelling is suitable, there are also carriages with mechanical or hydraulic levelling available as options. For double stacking the attachment approaches the

container from the front side (hooks). All carriages have support wheels to bear longitudinal stresses and sliding plates for lateral stresses.



Carriage for attachment with levelling in twistlocks, standard on DCF70-90 for single stacking



Carriage with mechanical levelling, available as option on DCF80-90 for single stacking.



Carriage with hydraulic levelling. Standard on DCF100 for double stacking and option on DCF80-90 for single stacking

Attachments

DCF70-90 are equipped with twistlock attachments. DCF100 is equipped with a C-hook attachment for double stacking. Both the hook and twistlock attachments have a hydraulic cylinder between the attachment and the carriage that allows ±600 mm side-shift.

The levelling function on the standard twistlock attachment is enabled by the mobility on each twistlock. This gives a simpler construction which offers increased reliability and easier servicing.

The locking and unlocking procedure is made easier through individual monitoring of the twistlocks or the hooks. To guarantee good visibility when handling the containers in dark conditions the working light is placed on the mast directed towards the locking device, independent of the spreader extension.

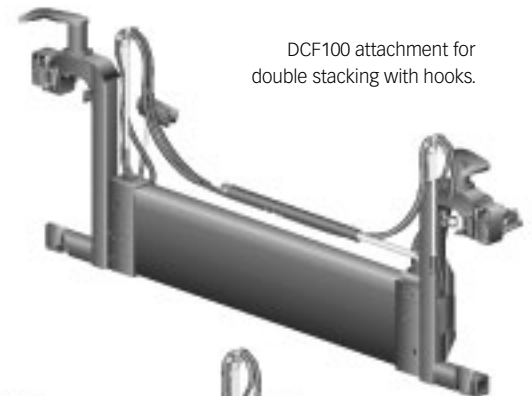

DCF100 attachment for double stacking with hooks.

Attachment for single stacking with twistlocks, available as option on DCF80-90.

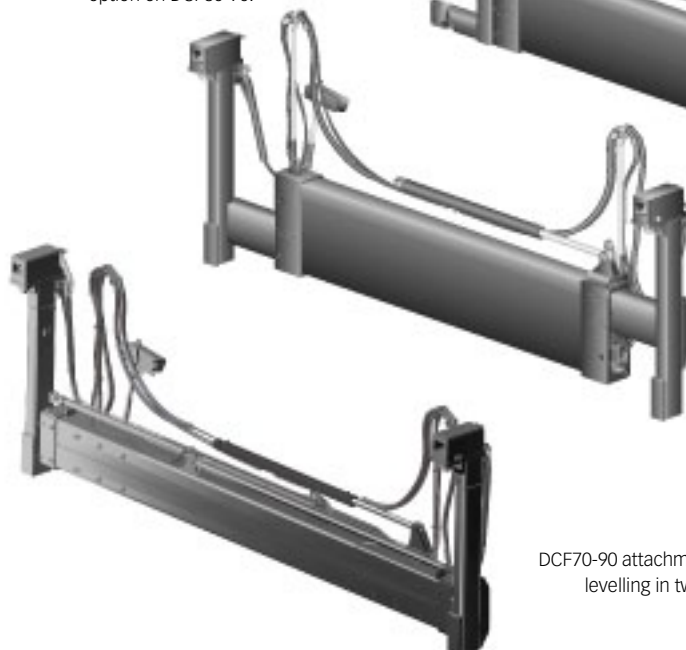

DCF70-90 attachment with levelling in twistlocks

Engineered to optimise performance

A key factor for productivity is the basic machine setup. We have put highest priority on overall technical reliability and how the components comes together, all functions must perform optimally even after heavy use.

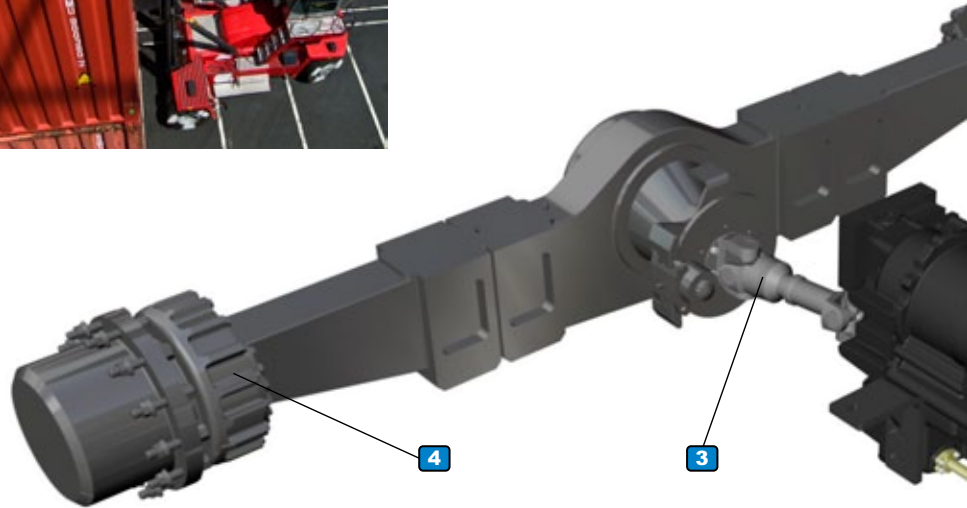
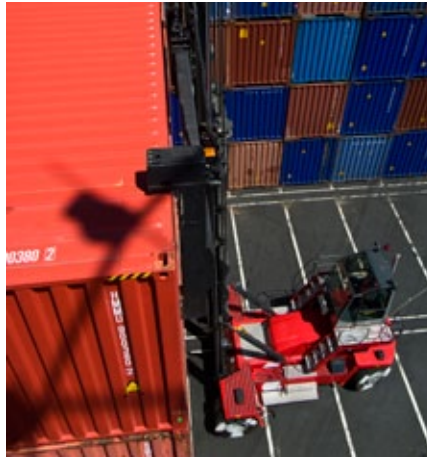

1 Engine

Kalmar products are fitted with the latest Volvo diesel engines which use Selective Catalytic Reduction (SCR) technology to deliver near-zero NO_x and harmful particulate emissions. This achieves compliance with the 2011 EU Stage IIIB and EPA Tier 4i emission regulations which govern all off-road equipment powered by engines of 130kW and above.

These engines also combine high power output and efficient fuel consumption. Furthermore, there is no increase in service intervals or costly downtime as the SCR system is designed to last the lifetime of the engine.

Volvo engines have strong reputation in container and industrial handling applications for delivering reliability and low running costs and the latest SCR system is well proven, having been used across the Volvo Group since 2006.

5 AdBlue tank and pump

The AdBlue tank has a volume of 20 l and is equipped with a level sensor which notifies the driver when its time to fill up the tank. The filling of AdBlue is usually done together with the filling of diesel. The AdBlue tank is heated by engine coolant and the AdBlue hoses are heated by electricity to prevent freezing in cold climates. (Freezing point of AdBlue -11C°).

6 SCR Catalyst

The SCR engines are optimised for efficient combustion, which provides the fuel efficiency and low particulate emission benefits. To combat the resultant NO_x emissions, AdBlue is injected into the exhaust gas. The exhaust gas and AdBlue then enter a catalytic converter, which turns the NO_x into harmless nitrogen gas and water vapour. The cleaning process of the catalyst is done automatically by the system during normal driving.

Steering system

The steering axle is built of high strength steel with a high structural integrity. The suspension points on the steering axle are maintenance free. The hydraulics that feed oil to the steering cylinder are optimised for enhanced driving sensation. The orbitrol and the priority valve jointly provide gentle, yet precise, steering movements.

2 Transmission

The transmission is electronically controlled in the DCF. It transfers power from the engine to the hydraulic pumps and drive line. The engine and gearbox control systems work together to find the optimum balance between power and fuel

economy at any given time. The transmission system consists of a torque converter and a gearbox. The gearbox is automatic, but can partly be shifted manually.

3 Drive line

The propeller shaft and drive axle transfer the power from the transmission to the driving wheels. The mountings on the propeller shaft are fitted with cross-flanges for optimum strength. The drive axle reduction is in two stages, differential and hub reduction. The engine provides maximum torque at the drive wheels, which spares the transmission.

4 Brakes

The Kalmar machine has, like its predecessors, the smooth, reliable and almost maintenance-free wet disc brakes. A temperature transmitter in the brake oil tank regulates the cooling fan.

The brake valve, which controls the oil feed to the brakes, is sensitive enough so that the driver can brake optimally. The parking brake is activated automatically when the ignition is turned off.

Wheels and tyres

Tyres are an important cost factor to consider when improving operational performance. Therefore, all models use identical sizes on both drive and steer wheels. This improves the machine stability, comfort and reliability and requires only one single spare tire.

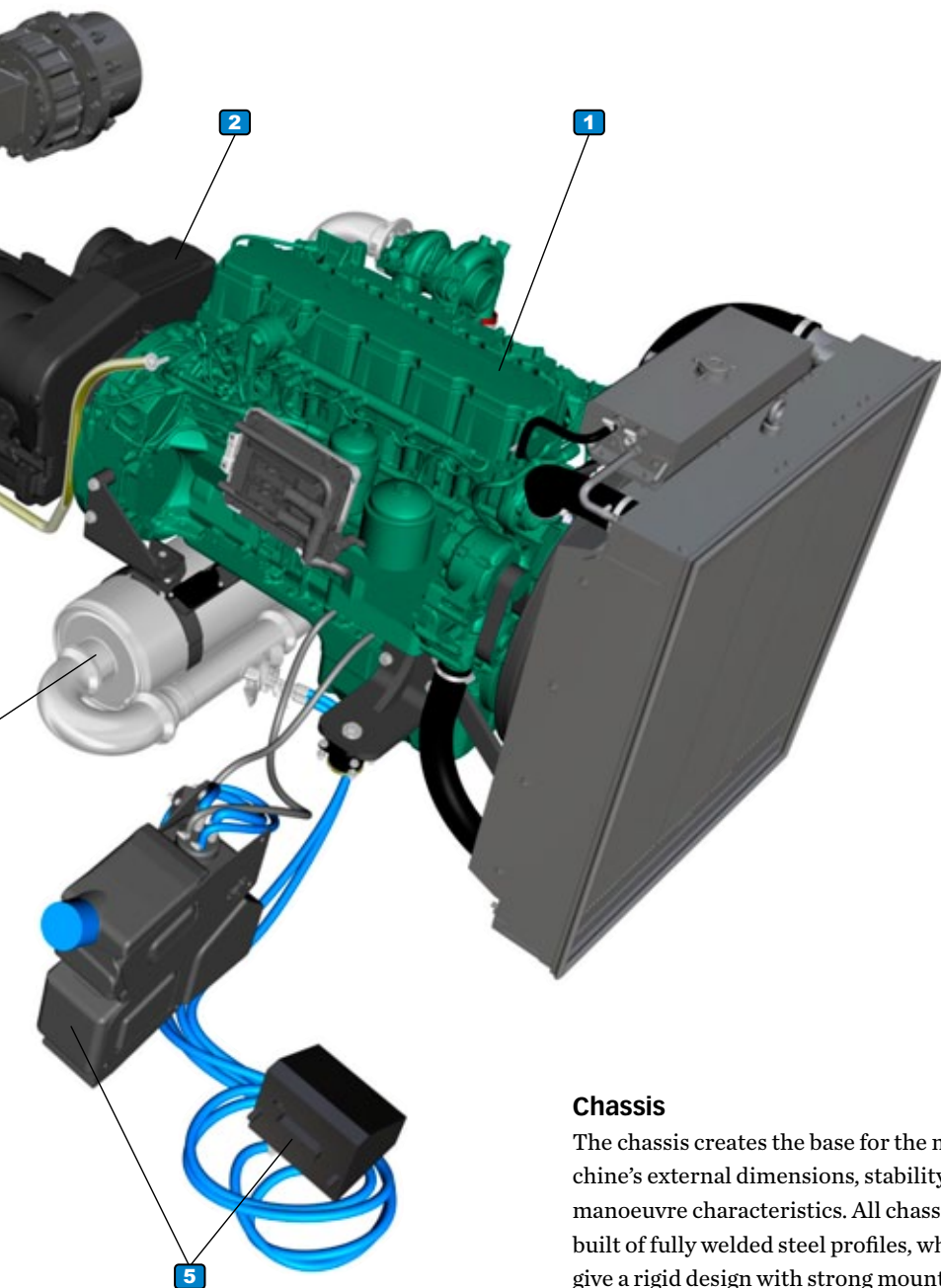

Chassis

The chassis creates the base for the machine's external dimensions, stability and manoeuvre characteristics. All chassis are built of fully welded steel profiles, which give a rigid design with strong mounting points for the drive axle and lift equipment. Stress concentrations have been eliminated for optimum tensile strength.

The chassis has a low profile for good visibility. The tanks are separately mounted and bolted to the chassis in a position that also contributes to good visibility. The cabin on each model is located for best visibility. The DCF70-100 series come in two different versions regarding the cabin position. Depending on market requirements the machines can be delivered with standard cabin height position or as an elevated version (only standard cabin available on DCF70).

Drive trains and performance

Drive train		Cummins QSB6,7 with Dana TE13000 (DCF70***)	Volvo TAD762VE with Dana TE17000 (DCF80-100)
Engine	Manufacturer, type designation	Cummins – QSB6,7 (Turbo-Intercooler)	Volvo – TAD762VE (Turbo-Intercooler)
	Fuel – type of engine	Diesel – 4-stroke	Diesel – 4-stroke
	Rating ISO 3046 – at revs (kW/hp – rpm)	129 – 2200	185 – 2200
	Peak torque ISO 3046 – at revs (Nm – rpm)	798 – 1400	1180 – 1400
	Number of cylinders – displacement (cm³)	6 – 5900	6 – 17,3:1
	Fuel consumption, normal driving (l/h)	12-14	15
		–	0,5
Gearbox	Manufacturer, type designation	Dana – TE13000	Dana – TE17000
	Clutch, type	Torque converter	Torque converter
	Gearbox, type	Powershift	Powershift
	Number of gears, forward – reverse	3 – 3	4 – 4
Alternator	Type – power (W)	AC - 1540	AC – 2400
Starting battery	Voltage – type	2×12 – 140	2×12 – 140
Driving axle	Type	Differential and hub reduction	Differential and hub reduction
Noise level	LpAZ (inside*) Spirit Delta, dB(A)	70	70
	LWA (outside**), dB(A)	–	–

* LpAZ according to EN1459 ** LpAZ according to 2000/14/EC *** DCF70 is not affected by Stage IIIB/ Tier4i legalizations

Performance – Cummins QSB6,7 with Dana TE13000		DCF70-40
Lifting speed	Unloaded (m/s)	0,48
	At 70% of rated load (m/s)	0,45
Lowering speed	Unloaded (m/s)	0,55
	At rated load (m/s)	0,55
Travelling speed, forward – reverse	Unloaded (m/s)	29 – 29
	At rated load (m/s)	25 – 25
Gradeability, max.	Unloaded (%)	28
	At rated load (%)	23
Gradeability, at 2 km/h	Unloaded (%)	24
	At rated load (%)	20
Drawbar pull	Max. (kN)	94

Performance – Volvo TAD762VE with Dana TE17000		DCF80-45	DCF90-45	DCF100-45
Lifting speed	Unloaded (m/s)	0,65	0,65	0,65
	At 70% of rated load (m/s)	0,45	0,45	0,45
Lowering speed	Unloaded (m/s)	0,55	0,55	0,55
	At rated load (m/s)	0,60	0,60	0,60
Travelling speed, forward – reverse	Unloaded (m/s)	29 – 29	30 – 30	30 – 30
	At rated load (m/s)	25 – 25	27 – 27	27 – 27
Gradeability, max.	Unloaded (%)	39	29	29
	At rated load (%)	32	23	23
Gradeability, at 2 km/h	Unloaded (%)	31	24	24
	At rated load (%)	26	19	19
Drawbar pull	Max. (kN)	144	127	127

Excellent operator comfort

To obtain the maximum out of your investment, you can never underestimate the importance of the drivers' working environment.

High productivity requires full driver concentration and efficiency to keep up handling speed, but also to avoid accidents causing injuries and costly damages. This is what ergonomics is all about. Comfort and awareness.

The F-generation cabin, the efficient Spirit Delta, offers excellent driver comfort with large display field on the instrument panel, generous glass surfaces that enable all-round visibility and low levels of noise and vibration.

We focus on four important ergonomic areas:

- Operation
- Visibility
- Sound and vibrations
- Climate

The result is a cabin where everything is optimised to improve driver performance. Consider this:

- Individually adjustable controls (mini-levers as standard or joystick as option), steering wheel and seat.
- Intuitively positioned instruments.
- Switches and buttons with lights.
- Comfort pedals.
- Electronic accelerator pedal.

- Central operation/warning display.
- Separately suspended and isolated cabin.
- Shock absorption to minimise vibrations.
- Maximum sound level inside is 72 dB (A).
- Generous interior dimensions and floor space.
- Optimised visibility – 360° all around.
- Electronically controlled heating/ventilation.
- Filters for fresh air and recirculation.
- High performance air conditioning system, optional.
- Pollen filter, optional.

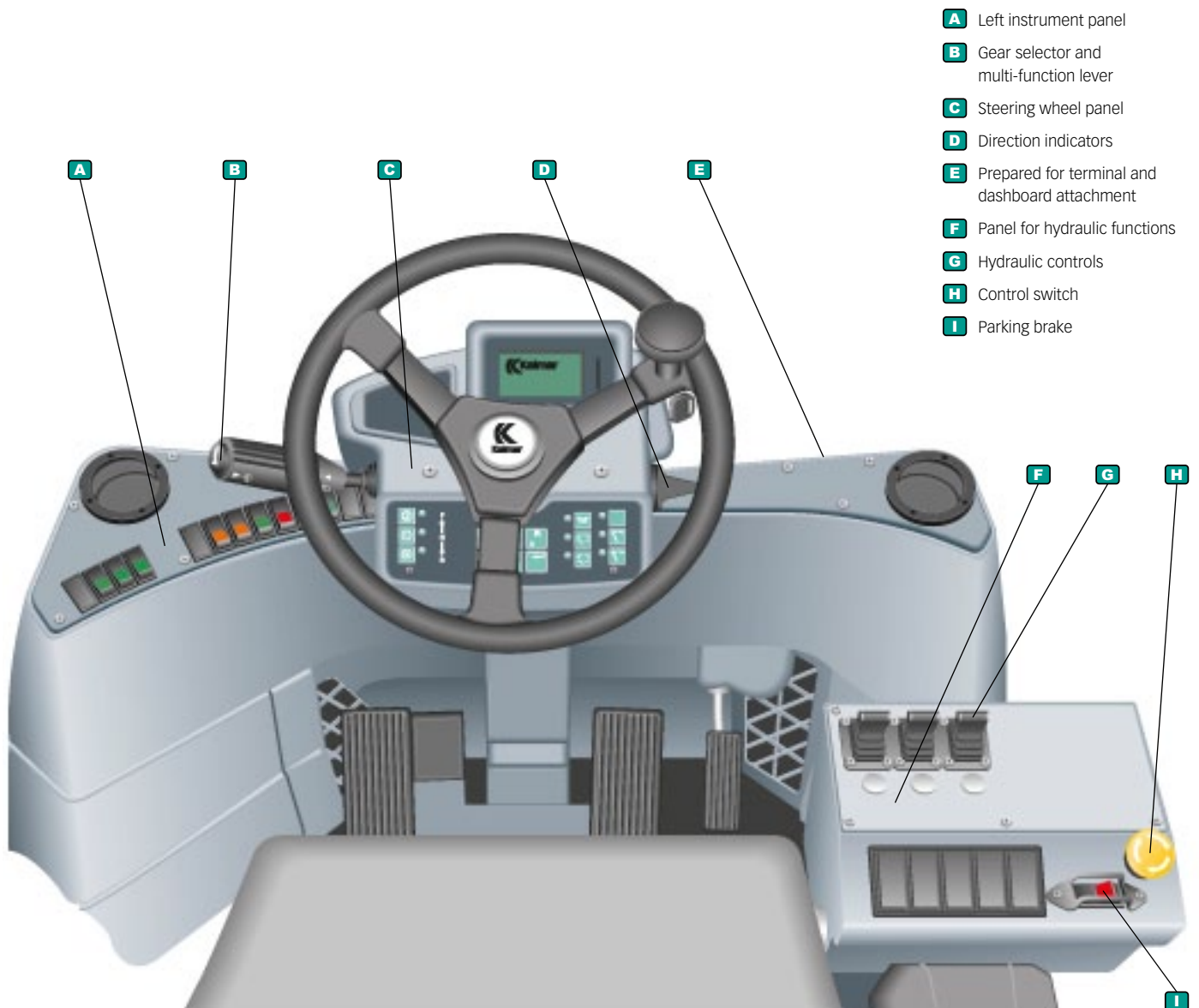

The simple way to reach new levels of utilisation

All vehicles today – cars, highway trucks, wheel-loaders, cranes etc – are designed with more and more sophisticated components and systems.

Each part interacts closely with the others and to reach the full potential requires computer assistance. This built-in intelligence is designed to support and leverage your handling operations, not confuse it.

The Kalmar F-series possesses a well proven, thoroughly tested and optimised control system, which supports your driver, mechanics and financial controller. And it is simple to use.

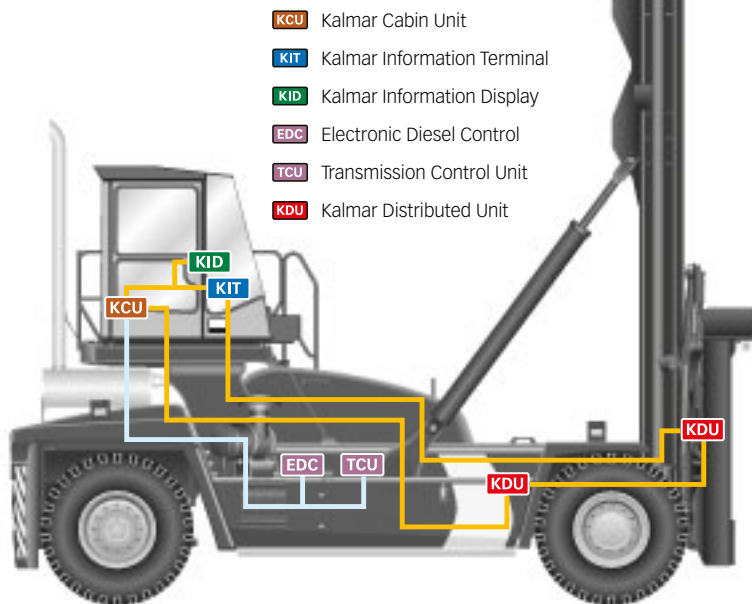

The communication network layout.

A well-distributed control system

Two things are needed for a command initiated by the driver to result in a particular function, or for several functions to work together: power supply and communication. The power-feed supplies the machine's electrical or electro-hydraulic functions with voltage. The communication system controls and checks that the functions have been activated, waits in standby mode or indicates faults.

Communication

The distributed power-feed and communication network consists of electrical components and a microcomputer-based system for controlling and monitoring the functions.

The most important components in the network are the control units (nodes).

They distribute control of the machine's functions. Each node has its own processor. The nodes integrate with each other and all communication; control signals and signal information are sent via data buses.

The nodes transmit their signals in messages on the network. Each message contains several signals and has its own address. Any units that need to know the status of a signal listen out for the address of the signal's message. All the nodes in the network listen to each other.

CAN-bus is a two-wire transfer of data and a definition of a bus type. CAN-bus technology has been chosen because it provides a reliable, robust transfer of data and is difficult to disrupt. CAN-bus loops have been used in Kalmar machines since 1995. The greatest benefit of using CAN-bus technology is that the amount of cabling can be reduced. All that is needed to establish communication are two data-bearing leads and two leads for feeding the nodes' processors. The network loop for both the CAN-bus and the nodes' processor feed are redundant.

The Kalmar Cabin Unit (KCU) is the control node for the entire network. There are several nodes, called KDUs (Kalmar Distribution Units), in the network. Each node is positioned near to the functions it is designed to deal with.

The Transmission Control Unit (TCU), which is the gearbox node, deals with the gearbox. The unit is connected in a separate CAN-bus loop with the EDC engine node (Engine Diesel Control) and KCU. The engine node controls the fuel injection and receives its control signals from its own transmitters on the engine.

Power supply

Power-feed for the functions differ from the feed required for communication and feeding of the nodes' processors. Each distribution unit (node) in the distributed network is fed voltage from one of the power distribution boxes. The distribution boxes are located inside the cabin and on one side of the frame. The distribution units (nodes) guide power from the distribution box to the required functions based on the instructions in the messages from the communication network.

Control functions support the driver

The driver and machine communicate very simply via the Kalmar Information Terminal (KIT) and the Information Display located right in front of the driver in the cabin. The two-way communication – from the driver to the machine and opposite – is handled by the KCU (Kalmar Cabin Unit) which is the control node for the entire network. Information to the driver comprises alarm warnings, operating details and action guided information. Messages, status, fault indications etc are presented on the Information Display (KID), while warnings and other monitoring indications are presented to the left.

Messages are only presented when they are relevant to the driver and the operation. The driver can focus on the job instead of checking meters and indicators.

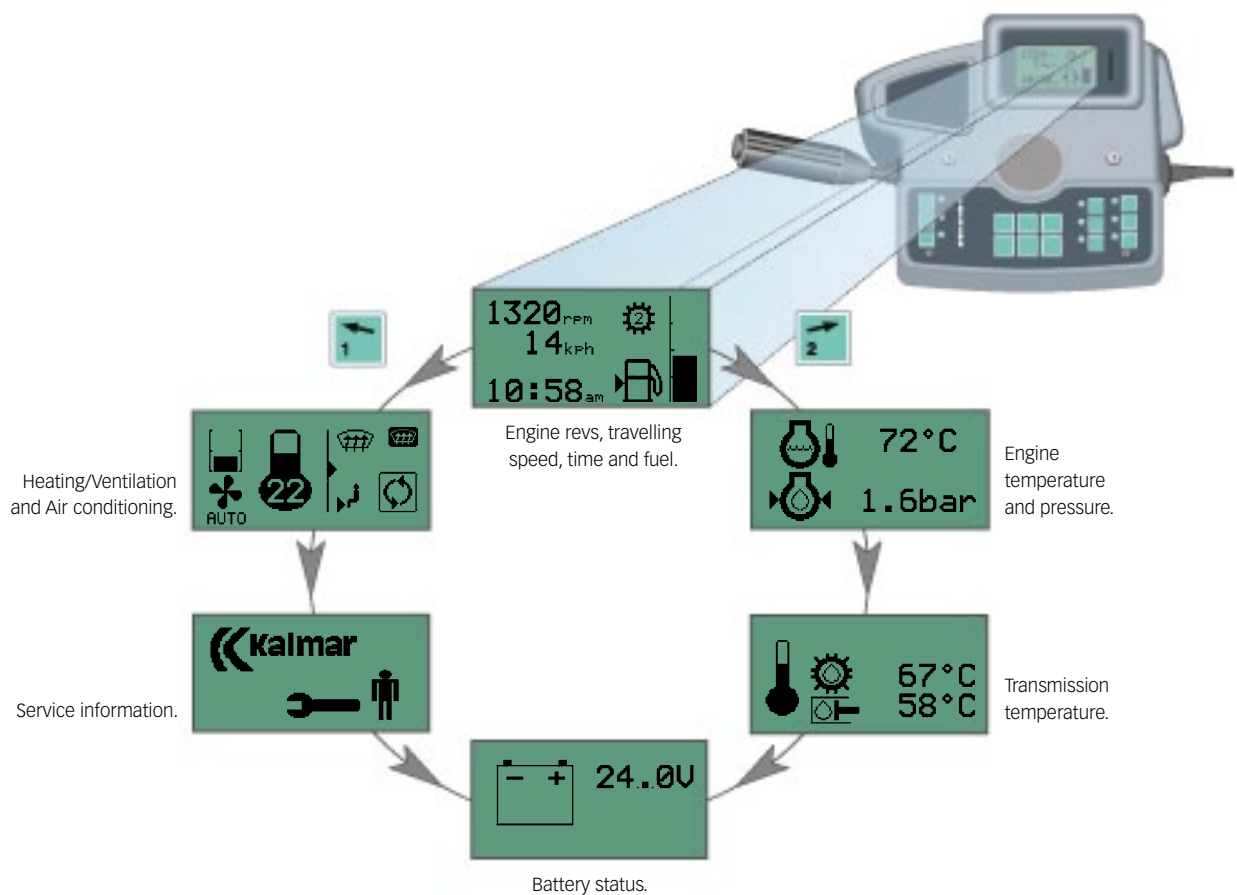

Superior availability ensures your investment is profitable

To understand the full potential of your investment requires being aware of the details, features and technical matters in a machine like the Kalmar empty container handler.



Fewer stops for planned maintenance

The service intervals are 500 hours. The DCF is designed for fast daily inspection and preventive maintenance. All check-points are easy accessible and concentrated to specific locations.

Lubrication free components or central lubrication points have been utilised. The wet disc brake system is practically maintenance free. The indicator and monitoring support built into our control system facilitate that the machine won't be misused or maintained incorrectly. The driver and mechanics will always get indications and guidance in time to avoid unnecessary and costly wear and tear or technical breakdowns. No unwanted stops.

A safe communication network.

The control and monitoring system, the redundant CAN-bus system is proven to be excellent in functionality and reliability. The network of control nodes allows for less wiring and connectors which reduces the number of sources of error.

The power-feed for each node and the transfer of control signals are independent of the other nodes, which means the risk of disruption becomes minimal. The redundant design means that there are always two paths to choose to maintain communication, which results in extra safety and reliability.

Reliability begins at the concept stage

One of the guiding principles in designing the DCF was to minimise the number of potential sources of error. Therefore the machines consist of as few components and moving parts as possible. The functionality and operational reliability is assured by extensive testing.



All hydraulic hoses are fitted with ORFS-couplings.

The hydraulic system is critical.

No other part of the machine is working so hard under continuous pressure. To secure the reliability we have minimised the number of hydraulic components and couplings.

To ensure optimum oil pressure and security regardless of the handling operation the hydraulic system is based on three variable pumps – one for the brake system, cooling and filtering, one for working hydraulics and one supporting both steering and working hydraulics.

The distribution of pressure between working hydraulics and steering is done by the priority valve which ensures that the steering always receives enough pressure. The hydraulic oil pump for load handling is disconnected during forward driving, to use the engine power to its best.

All three pumps interact together, using the same oil tank and filters, which are located inside the tank. The system is equipped with one oil cooler and a sepa-

rate fan to secure the right oil temperature, to match the hydraulic brake heat generation as well as feeding the overall system during tough handling cycles.

Oil supply and temperature control is handled through Kalmar's distributed control system. All indications are presented when appropriate on the Kalmar Information Display (KID) in the cabin.

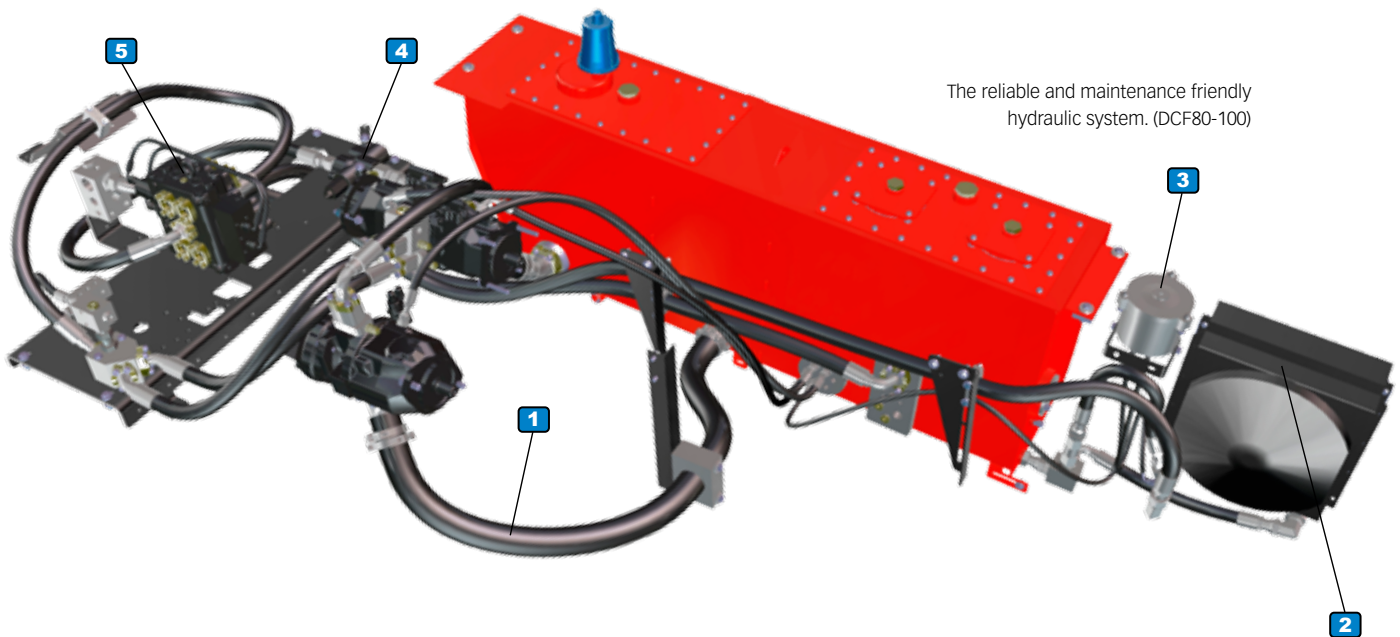

Other improving features:

- 1** The large dimensions of hydraulic hoses improves the hose's lifetime (slower flow, less friction and less heating).
- 2** Thermostatic cooling improves the oil lifetime (temperature control, optimised working temperature).
- 3** High density filter improves the oil lifetime (clean oil).
- 4** ORFS – leak proof couplings all around improves reliability (minimises leakage).
- 5** All main hydraulic components at ground level are gathered on a separate plate, bolted to the chassis and therefore simple to remove.

Global presence and local service bring
our products and solutions closer to our customer.



Cargotec improves the efficiency of cargo flows on land and at sea – wherever cargo is on the move. Cargotec's daughter brands Hiab, Kalmar and MacGregor are recognised leaders in cargo and load handling solutions around the world. Cargotec's global network is positioned close to customers and offers extensive services that ensure the continuous, reliable and sustainable performance of equipment. Cargotec's class B shares are quoted on the NASDAQ OMX Helsinki. www.cargotec.com



Cargotec Sweden AB
Torggatan 3
SE-340 10, Lidhult, Sweden
tel. +46 372 260 00
fax +46 372 263 90
www.cargotec.com