

tractors  
fork lift trucks  
empty container handling ▶  
reach stackers  
straddle carriers  
steel coil handling  
pick & carry crane

products



C.V.S. spa

via Emilia, 20/22  
29010 Roveleto di Cadeo  
Piacenza - Italy

tel. +39.0523.503511  
fax +39.0523.500439

[www.cvsferrari.com](http://www.cvsferrari.com)  
[info.mktg@cvsferrari.com](mailto:info.mktg@cvsferrari.com)



## Technical Information

# Empty Container Handling

**FERRARI**  
**F 258**

SPECIFICATION	01 Manufacturer				CVS
	02 Model				<b>FERRARI 258.6</b>
	03 Lifting capacity	First Row/Second Row		Kg.	12000/10000
	04 Load Center	First Row/Second Row		mm.	1550/3850
	05 Power unit				Diesel engine
	06 Steering				Steering wheel in the cab
	07 Tyre type	Front / Rear			Pneumatic
	08 Wheels	Number at Front/Rear (*=driven)			4*/2
DIMENSIONS	09 Lifting Height	Under Spreader - First Row		mm.	15875
	10 Width of Spreader	20 Ft.		mm.	6052
	11 Side Tilting	Mechanical		Deg.	+/-3
	12 Rotation	Hydraulic-		Deg.	-95 + 185
	13 Side shifteing	Max		mm.	+/- 800
	14 Boom Angle	Min / Max		Deg.	0 / 65
	15 Overall dimensions	Length		mm.	10455
		Width		mm.	4143
		Boom height, Min.		mm.	4130
	18	Boom height, Max		mm.	18290
	19	Seat height		mm.	2260
20	Min. dist. spreader from ground		mm.	1140	
21 Turning radius	Inner/Outer		mm.	430/6600	
22 Distance from front axle	Center to load, first row		mm.	2250 - 3390	
23 Aisle for 90° stacking	Incl. 200 mm. safety margin		mm.	13380	
PERFORMANCE	24 Stability	DIN 15018 (Yes/No)			Yes
	25 Speeds	Travelling F. & R. Laden/Unladen		km/h	24.6/26
		Lifting (empty/booster/laden)*		m/s	0,47 / 0,57 / 0,32
		Lowering		m/s	0.40
	28 Drawbar pull	Max - Laden		kN	185
	29 Gradeability	Cont. at 2 Km/h - Laden		%	28
Max at 0 km /h - Laden			%	35	
WEIGHTS	31 Gross vehicle weight			Kg.	41700
	32 Axle load - Front	Unladen		Kg.	23800
		Laden L1		Kg.	37800
	33 Axle load - Rear	Unladen		Kg.	17900
Laden L1			Kg.	15900	
TYRES BRAKES CHASSIS	34 Tyres	Number - Front/rear			4/2
	35	Size - Front		ins.	14.00-24 28 PR
	36	Size - Rear		ins.	14.00-24 28 PR
	37 Wheelbase			mm.	5000
	38 Track	Between centres - driven wheels		mm.	3288
	39 Ground clearance	Mid-way along the wheelbase		mm.	260
	40 Foot brake system	Type/brake wheels			Multiple wet disc brakes/ Driven Wheels
STEERING SYSTEM	41Type				Hydrostatic
DRIVING SYSTEM	42 Engine	Manufacturer - Type			VOLVO TAD 720 VE
	43	Rating - DIN 6271		kW/(hp)	174(237)
	44	Rated Speed		RPM	2300
	45	Peak Torque - at engine speed		Nm/RPM	854/1400
	46	Number Cylinders - displacement		cm3	6/7150
	47	Compression Ratio			19:1
	48	Fuel Consumption (Average)		l/h	10
	49 Alternator	Type - Rating		A	140
	50 Starting Batteries	Voltage - Capacity		V/Ah	2 x 12 V / 180
	51 Drive Axle	Type			With double reduction
	52 Gear Box	Type-number of gears forwar/rev.			Clark - 4/4
	53 Clutch	Clutch type			Torque converter
	54 Hydraulic pressure	For attachments		Bar	140
55 Sound Level		Inside cabin (EN 12053)		dB(A)	75

\* Lifting booster optional

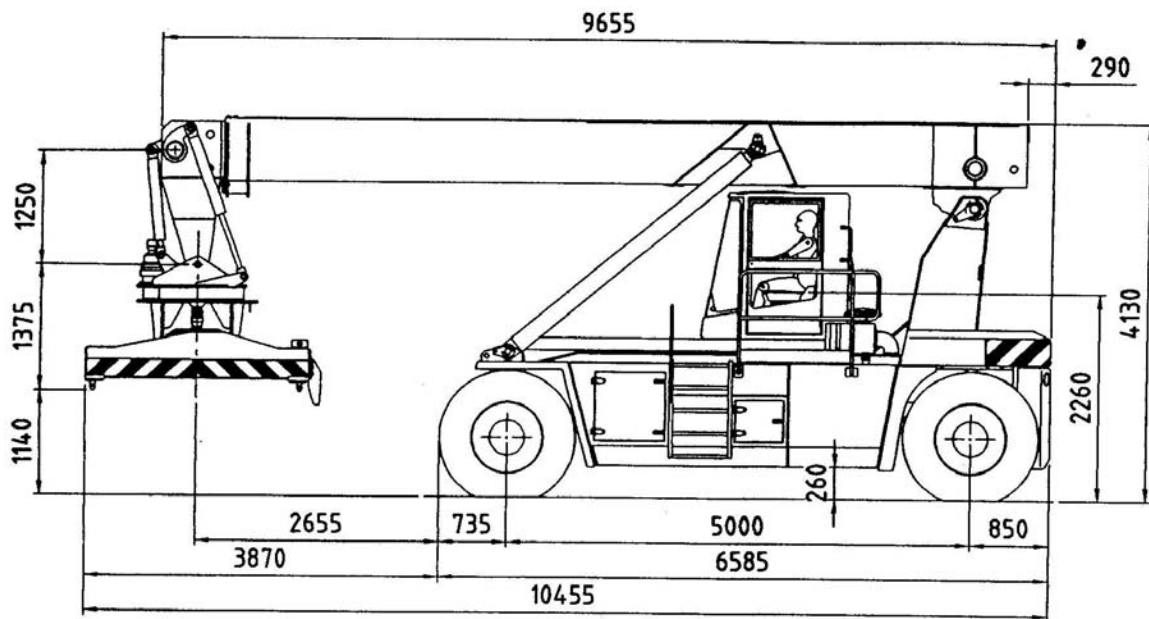
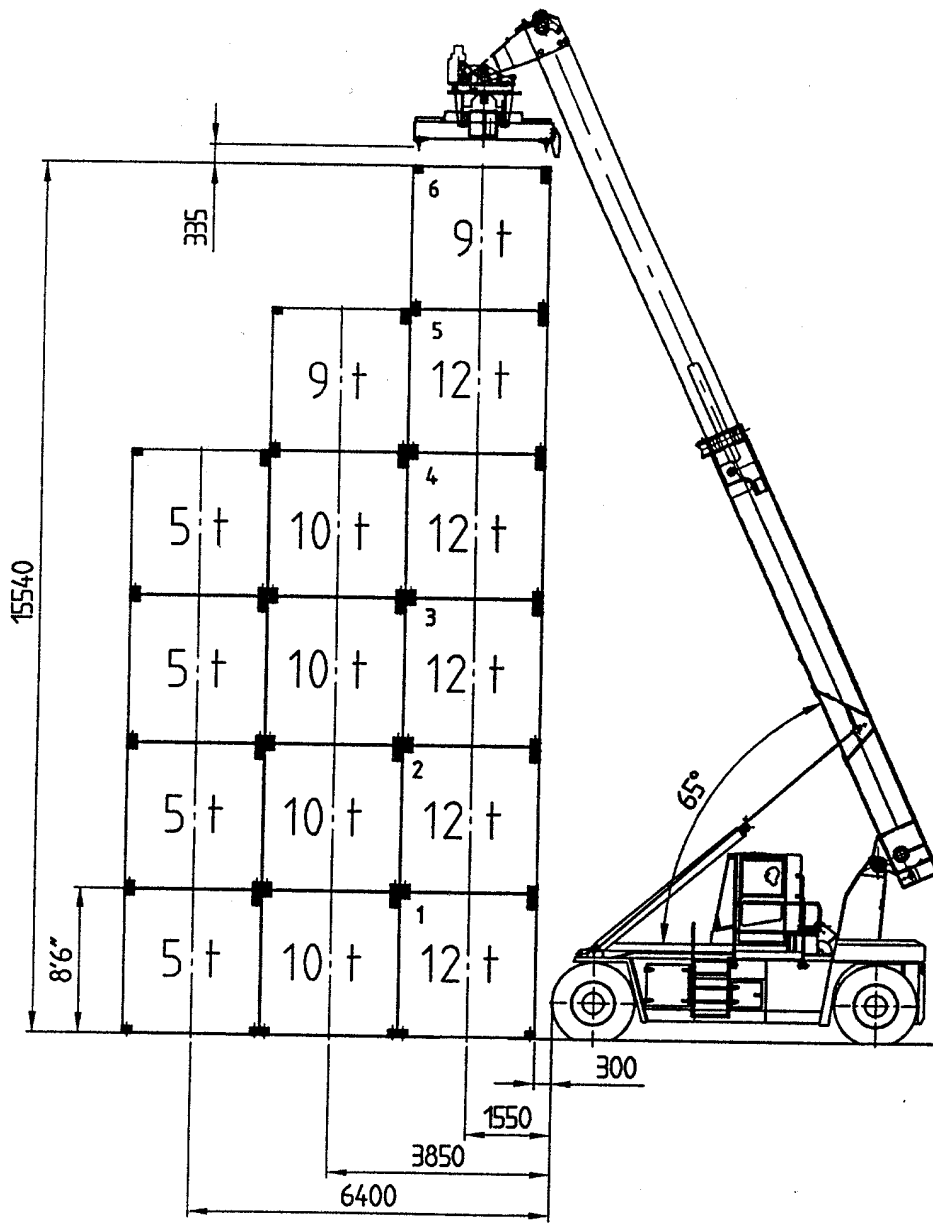

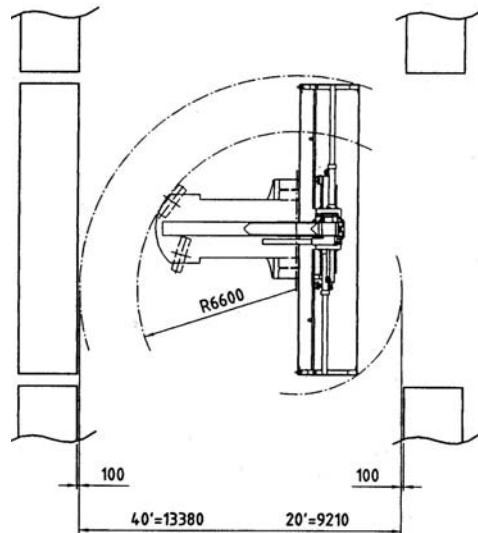
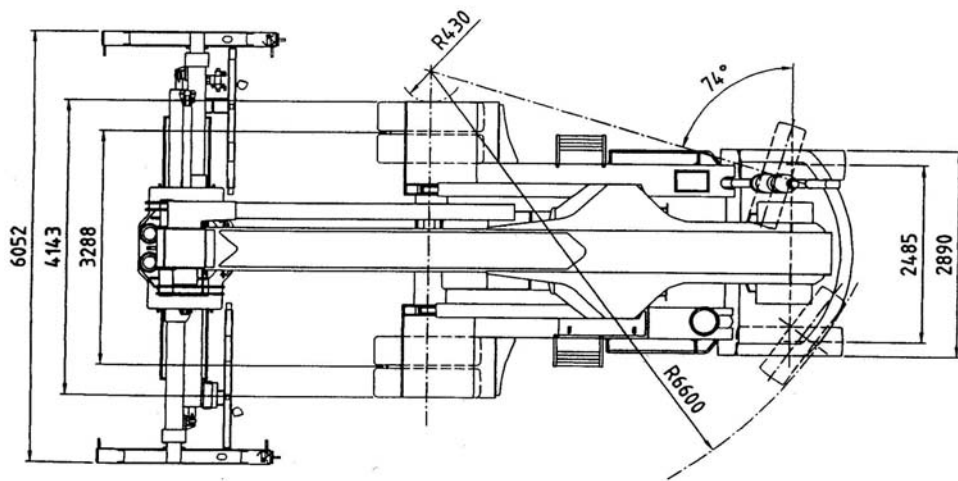

**CHASSIS**

All welded box type. Highest strength. Torsion resistant structure.

**ENGINE**

VOLVO TAD 720 VE .  
Euromot step 2 . Low pollution level. Eurostandard . Lowest fuel consumption and best performances.

**TRANSMISSION**

CLARK 32000  
Integrated torque converter and power shift . 4 Speeds forward and 4 speeds reverse

**FRONT AXLE**

Epicicloidial hub reduction plus central reduction (bevel gear and pinion). Wet discs brakes.

**REAR AXLE**

Articulating axle with double acting single cylinder. Full hydrostatic steering system (Orbitrol).

**HYDRAULIC SYSTEM**

Variable displacement pumps. Load sensing distributors controlling, lifting and steering. Hydraulic and proportional joystic. Oil cooling system .

**ELECTRICAL SYSTEM**

The most reliable and easy to service. 24 V. - Two 12 V. batteries of low maintenance type. High performance alternator.

**BOOM**

High torsion. High quality steel. New design - One basic section and one telescopic section.

**TOP SPREADER:**

High quality steel. Compact and precise. Telescoping from 20' to 40'. All functions controlled from cab. Safety sensors on four corners.

The illustrations and data contained in this brochure are not binding. The manufacturer reserves the right to make changes for any reason while not altering the primary specifications



**FERRARI**



Distributed & Serviced by:

C.V.S S.p.A. - Via Emilia - 29010 Roveleto di Cadeo (PC) ITALY  
Tel. ++39.0523.503511 - Fax ++39.0523.500439  
E-mail: info.mktg@cvsferrari.com





