

Stand-in lowlifter truck 2.0 ton

BT LEVIO

S-series

LSI200

LI-ION

Lithium-Ion Energy System



Stand-in lowlifter truck

Specifications					LSI200
Identification	1.1	Manufacturer			Toyota
	1.2	Model			LSI200
	1.3	Drive			Electric
	1.4	Operator type			Stand-in
	1.5	Load capacity/rated load	Q	kg	2000
	1.6	Load centre	c	mm	600
	1.8	Load distance, front axle to fork face	x	mm	957/913*
	1.9	Wheelbase	y	mm	1600
	Weight	2.1	Service weight without battery		kg
2.2		Axle load, with load, drive/castor/support arm wheel		kg	1040/1780
2.3		Axle load, without load, drive/castor/support arm wheel		kg	618/197
Wheels	3.1	Drive/castor/fork wheel			Polyurethane*
	3.2	Wheel size, front		mm	ø250x92
	3.3	Wheel size, rear		mm	ø85x95*
	3.4	Additional wheel size		mm	ø140x86
	3.5	Wheels, number front/rear (X = driven wheels)			1x+ 2/2 or 4
	3.6	Track width, front	b ₁₀	mm	460
	3.7	Track width, rear	b ₁₁	mm	370
Dimensions	4.4	Lift	h ₃	mm	140
		Lift height	h ₂₃	mm	225
	4.8	Stand height	h ₇	mm	262
	4.15	Height, fork lowered	h ₁₃	mm	85
	4.18	Overall chassis height	h ₁₅	mm	1575
	4.19	Overall length	l ₁	mm	1972
	4.20	Length to face of forks	l ₂	mm	822
	4.21	Overall width	b ₁	mm	790
	4.22	Fork dimensions	s/e/l	mm	78/180/1150*
	4.25	Width over forks	b ₅	mm	550*
	4.32	Ground clearance, center of wheelbase	m ₂	mm	30
	4.33	Aisle width for pallets 1000x1200 crossways	A _{st}	mm	2602
	4.34	Aisle width for pallets 800 × 1200 lengthways	A _{st}	mm	2468
4.35	Turning radius	W _a	mm	1800	
Performance data	5.1	Travel speed, with/without load		km/h	10/12,5
	5.2	Lift speed, with/without load		m/s	0,037/0,052
	5.3	Lowering speed, with/without load		m/s	0,06/0,035
	5.8	Max. gradeability, with/without load ¹⁾		%	8/18
	5.9	Acceleration time (over 10 m)		s	5,5
	5.10	Service brake			Electromagnetic
Electric motor	6.1	Drive motor rating S2 60 min		kW	2,8
	6.2	Lift motor rating at S3 20%		kW	1,4
	6.4	Battery voltage/nominal capacity K _s		V/Ah	24/210,300,420
	6.5	Battery weight		kg	29, 44, 58
	6.6	Energy consumption acc to EN16769		kWh/h	0,37
	Others	8.1	Type of drive control		
8.4		Sound level at the driver's ear according to EN12053		dB(A)	66

*Alternatives are available and come with other values.

All data are based on table configuration. Other configurations may give other values.

Truck performance and dimensions are nominal and subject to tolerances.

Toyota Material Handling Manufacturing Sweden AB products and specifications are subject to change without notice.

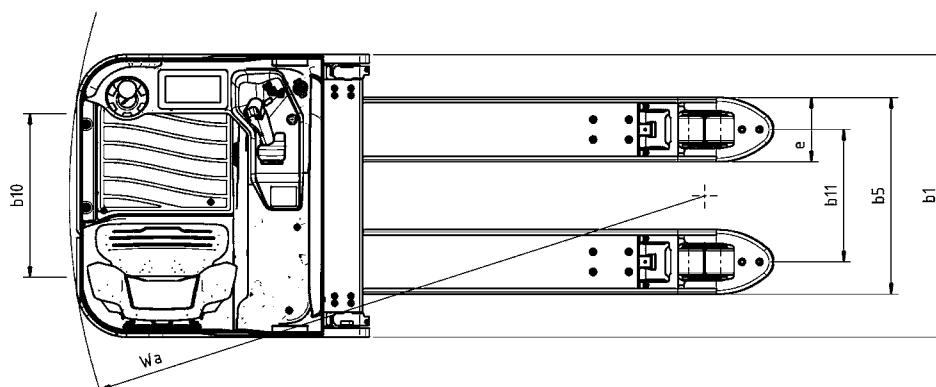
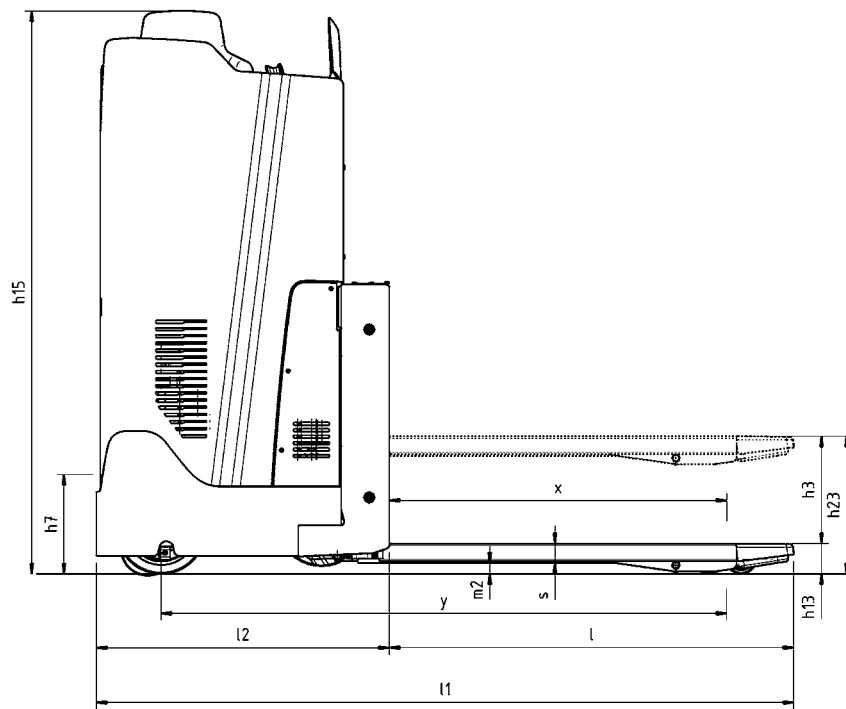

Truck features:

- Fingertip controls
- Adjustable sit/stand chair
- 180° or 360° steering mode
- Driver detection system
- Multifunction colour touchscreen
- Carefree Li-Ion energy solution
- Automatic speed reduction in curves
- Blue LED warning light option
- Cold store option
- Automatic deceleration
- Automatic parking brake
- Electronic braking system
- Electronic regenerative brakes (motor)
- Electronic speed control

