

GLOBAL SALES NETWORK

ELECTRIC TOW TRACTOR

20-25t

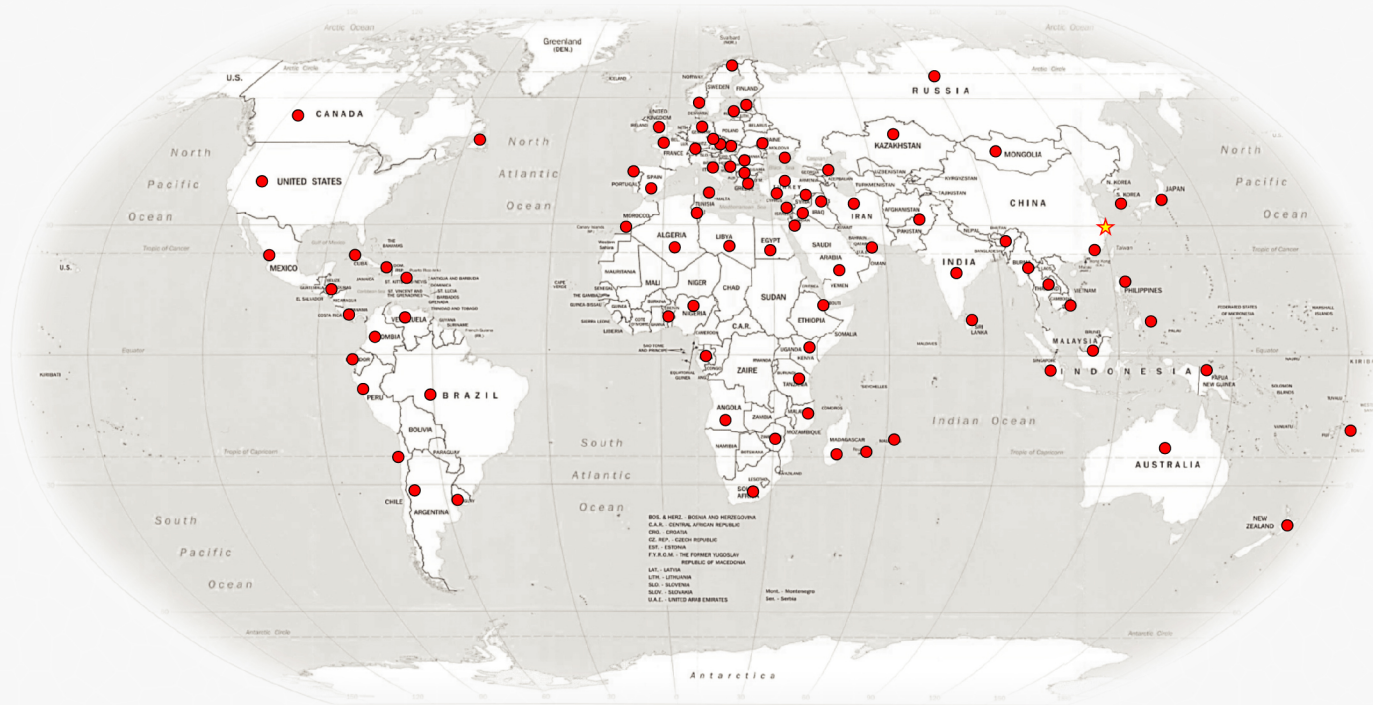

CE CERTIFICATE



ISO14001: 2004



ISO9001: 2008

HANGCHA GROUP CO., LTD.
(Zhejiang Hangcha Imp.&Exp.Co.,ltd.)

www.hcforlift.com

Add:398 Shi Qiao Road, Hangzhou Zhejiang province, China(310022)
 Factory site:No.88,Donghuan Rd.,Economic Development Zone Lin'an,Zhejiang,China(311305)
 Fax: +86-571-88926789 88132890
 E-mail: whsales@hcforlift.com
sales@hcforlift.com

HANGCHA GROUP CO., LTD. Reserves the right to make any changes without notice concerning colors, equipment, or specifications detailed in this brochure, or to discontinue individual models. The colors of trucks, delivered may differ slightly from those in brochures.

2014 VERSION 1/ COPYRIGHT 2014/04

HANGCHA GROUP CO., LTD.

Appearance

- Body choosing modern large circular arc streamline surface model, is in accordance with international design trend. It's suitable for tractor, pulling, pushing and handling operations.

Reliability

- The battery is dropped down to the lowest part of frame, this gives the tractor excellent stability because low center of gravity.

Safety

- High frequency MOSFET controller provides accurate control of travelling, lifting, and better adjustable performance and better match with the motor. Secure stopping on ramp function is also provide.

Thanks to MOSFET controller. Motor brake is for regenerative braking during deceleration, direction, changing, and downward slope. The regenerative braking is more energy saving and effectively.

- X-type arrangement of dual piping, distribute the pressure by front and rear, the braking system is safe, stable and reliable. The design of vacuum drum ensure the braking system working as usual.
- The electrical switch can cut off the power.

Comfort

- Adopt the new digital dashboard and rocker switch, the status of vehicle be clear at a glance, simple, reliable and intuitive.
- Adopt horizontal cylinder steering axle and full hydraulic steering gear, the steering force is less than 10N. Optional synchronous steering system provides good stability, especially suitable for long-distance road in the airport and so on.
- The advanced floating suspension system and long wheelbase design, ensure the comfort of the vehicle.
- The advanced floating suspension system and long wheelbase design, ensure the comfort of the vehicle.



- Optimized design structure to offer a good visibility and easier operation, provides good sealing, sound insulation, heat insulation, vibration isolation. Low step and capacious room will be much appreciated by operator who have to get on and off.
- Adjustable steering wheel and 150mm adjustable distance of seat ensure driver maximum comfortable and minimum fatigue.

Advance

- New AC system provide more power, more precise performance of speed control, more safety and reliability, regenerative system.

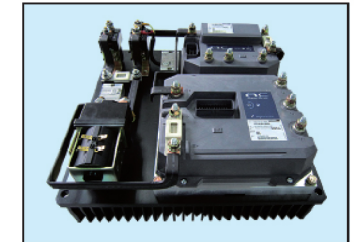

Advanced full-AC power system, full closed, compulsory air-cooled, reliable and safe

- High effective AC system prolong the working time.
- Adopt the international first-class brand of LCD, with the battery indication, self diagnosis function, it's no need handset unit. The display can make changes to the electronic control parameters, you can read the fault code clearly from it.
- There are switch in the rear: Including Forward/Reverse inching switch and emergency disconnect switch.

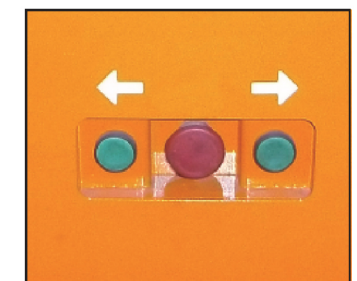

- There are two methods to exchange battery: Lifting-exchange and side-exchange battery, it's convenient for user.
- The controller is enclosed to avoid dust and water, it can provide forced cooling, heat dissipation and control the direction of the wind.
- The size of platform of the rear : 1300mm× 1638mm, it can be used as loading platform, maximum load weight is 500Kg.

Environmental protection

- Low noise, low shake, energy efficient, environmental protection.
- Vehicle use non-asbestos material.

Easy maintain

- Electric parts adopt international famous brand are to ensure the reliability of the performance.

- Maintenance free driving motor is no need to replace the carbon brush, low service cost.
- You can open and close the battery cover hood for daily checkup the battery, motor and controller. It's easy to access inner of battery cover for maintenance.

Standard Feature

- Emergency disconnect switch
- Head lamp

- Turning lamp
- Rear combined LED
- Sun shield
- Front wiper
- Front wiper washer fluid
- Adjustable device for steering wheel
- Horn
- Buzzer
- Retroreflector
- Rear view mirror
- Dome light
- Fan

- Large rubber pedal pad
- AC drive system
- Full hydraulic steering
- Hand grip
- Full closed cab
- Vacuum assistant braking system
- Standard seat
- Standard battery
- Side-exchange battery
- Toolbox
- Inching switch
- Traction pin

Options

- Warning lamp
- High capacity national battery
- Excellent performance import battery
- Battery charger
- Rear working lamp
- Speed limit alarm
- Different height of traction pin
- Semi-closed cab
- Steam air heater
- Synchronous steering system
- Hydraulic assistant brake system
- Front bumpers
- Front pothook
- Extinguisher
- Solid tyre
- Suspension seat
- Speed limit
- Rear wiper
- Rear wiper washer fluid
- Long-distance control system
- Full hydraulic brake
- Tractor pin operation device



20-25t electric tow tractor specification

Manufacture				HANGCHA				
Model				QSD20-D3 QSD20-C3	QSD25-D3 QSD25-C3	QSD20-D2T QSD20-C2T	QSD25-D2T QSD25-C2T	
Performance	1	Pothook Drawbar Pull(1 Hour)	N	5000	6300	5000	6300	
	2	Max.Drawbar Pull	N	16000	20000	18000	21000	
	3	Tow weight in dry concrete level off the road	Kg	20000	25000	20000	25000	
	4	Max.Travel speed	Km/h	25	25	20	20	
	5	Turning radius	mm	2825	2825	2825	2825	
	6	Gradeability without load	%	30	30	30	30	
Weight	7	Weight distribution	Front wheel	Kg	1640	1600	1640	1600
	8		Rear wheel	Kg	1910	2150	1910	2150
	9	Sevice weight	Kg	3550	3750	3550	3750	
Tractor Motor	10	Rated capacity/r./min	KW/(r/min)	23/2063	23/2063	23/2063	23/2063	
	11	Rated Voltage/current	V/A	55/295	55/295	55/295	55/295	
	12	Excitation mode		AC	AC	AC	AC	
	13	Quota		60 Minutes	60 Minutes	60 Minutes	60 Minutes	
Steering Motor	14	Insulation class		F	F	F	F	
	15	Rated capacity/r./min	KW/(r/min)	1.0/1400	1.0/1400	1.0/1400	1.0/1400	
Controller	16	Excitation mode		DC	DC	AC	AC	
	17	DANAHER	D	MOSFET/Semi-AC	MOSFET/Semi-AC	MOSFET/Full-AC	MOSFET/Full-AC	
Dimensions	18	CURTIS	C	MOSFET/Semi-AC	MOSFET/Semi-AC	MOSFET/Full-AC	MOSFET/Full-AC	
	19	Overall length	mm	3140	3140	3140	3140	
	20	Width	mm	1300	1300	1300	1300	
	21	Height	Without cab	mm	1200	1200	1200	1200
			with cab	mm	1760	1760	1760	1760
	23	Load platform	Length	mm	1630	1630	1630	1630
			Height	mm	1070	1070	1070	1070
	25	Wheel base	mm	1490	1490	1490	1490	
	26	Thread	Front	mm	1124.5	1124.5	1124.5	1124.5
			Rear	mm	1100	1100	1100	1100
28	Ground clearance	mm	140	140	140	140		
29	Towing coupling height	mm	550/450/350	550/450/350	550/450/350	550/450/350		
Other	30	Tyres	Front		6.50-10-10PR/2	6.50-10-10PR/2	6.50-10-10PR/2	6.50-10-10PR/2
	31		Rear		7.00-12-12PR/2	7.00-12-12PR/2	7.00-12-12PR/2	7.00-12-12PR/2
	32	Battery	Voltage/Capacity	V/A.H	80/500	80/500	80/500	80/500
	33		Serviec weight	Kg	1350	1350	1350	1350
34	Service braking		Vacuum power brake	Vacuum power brake	Vacuum power brake	Vacuum power brake	Vacuum power brake	

Remark:Semi-AC:Tractor motor(AC)+Steering motor(DC), Full-AC:Tractor motor(AC)+Steering motor(AC).

Dimensions

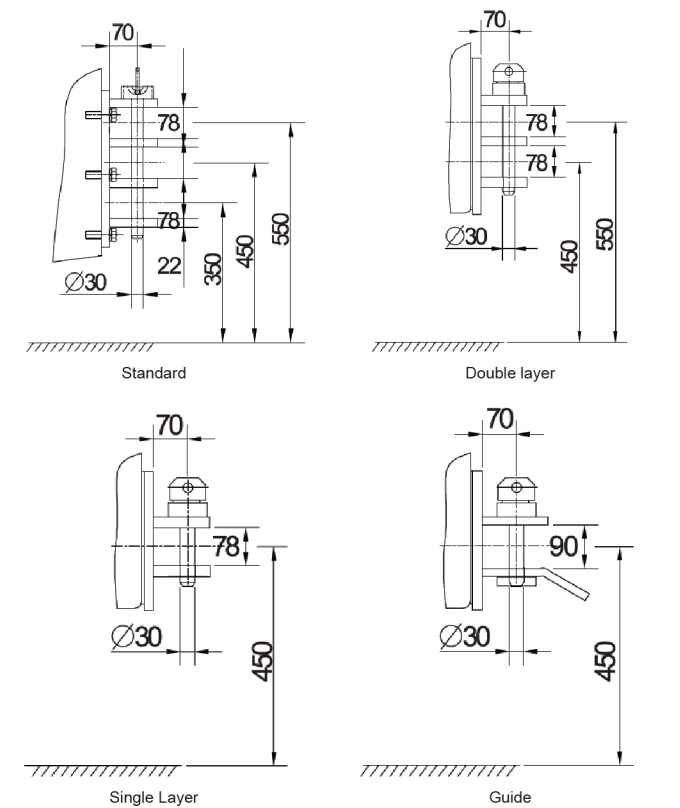
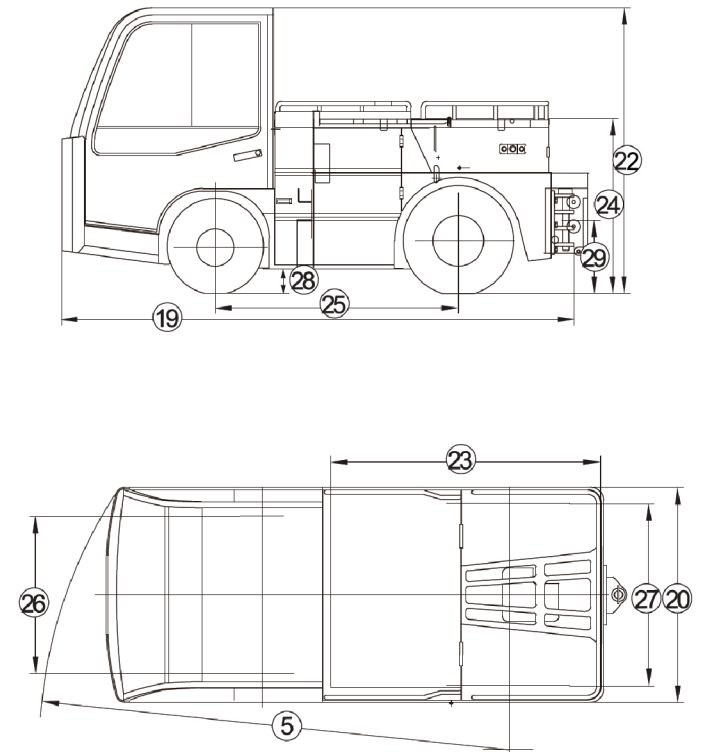

Dimensions & Type of pin

20-25t electric tow tractor :Tow weight/Grade Unit:Kg

Tow weight		Model	QSD20	QSD25
Level load	0°		20000	25000
	1°		12500	15500
	2°		10300	12900
	3°		8800	10900
	4°		7500	9400
	5°		6500	8100
Grade (Degrees)	6°		5700	7100

Remark: 1.5 Min start on slope, dry concrete level off the road(Rolling resistance coefficient of 0.018).
2.Specifications are subject to change without notice.

Battery configuration table

Factory	Import				Domestic	
	HOPPECKE	HAWKER	FAAM	GS	淄博	迅启
Type/Capacity	500	500	500	480	480	520
	560	560	580	560	560	580
	600	●	●	600	600	600
	620	620	620	●	●	●
	●	●	640	●	●	●