



## HANGCHA GROUP CO., LTD.

Factory site: 666 Xiangfu Road,  
Hangzhou, Zhejiang, China (311305)

Tel: +86-571-88926735 88926755  
Fax: +86-571-88926789 88132890

[sales@hcforklift.com](mailto:sales@hcforklift.com) [www.hcforklift.com](http://www.hcforklift.com)



Follow us on  
Facebook



Follow us on  
YouTube



Follow us on  
WeChat



Download "Hangcha  
Forklift" App



ISO14001:2015



ISO9001:2015



HANGCHA trucks conform  
to the European Safety  
Requirements.

# XH SERIES

HIGH-VOLTAGE LITHIUM BATTERY FORKLIFT

With capacity of 20,000 to 25,000kg

# BECOME THE FORKLIFT MEETING YOUR DIFFERENT NEEDS.

VOLTAGE

**541 V**

CHARGING TIME (20-100%)

**1.0 Hour**

VEHICLE WATER RESISTANCE

**IPX4**



TRAVEL SPEED

**25km/h**

SPEED MODELS

**3** S/P/E mode  
(Super/Power/Eco)

PROTECTION RATE

**IP67**

## XH SERIES HIGH-VOLTAGE LITHIUM BATTERY FORKLIFT

Your reliable, powerful and connected working machine.

XH series high-voltage counterweight lithium battery forklifts are new series of high-voltage counterweight lithium battery forklifts independently developed by Hangcha relying on the new energy automobile voltage platform for the first time based on the deep understanding of electric forklifts and internal combustion forklifts for decades by breaking through the traditional design concept.

The series of models redefine electric forklifts in terms of efficiency, power and reliability, surpassing the electric forklifts with internal combustion in all aspects.





# FASTER EFFICIENCY

Through disruptive battery and fast charging technology, the charging time is greatly shortened.

Fast charging makes it possible for the whole vehicle to work continuously, shortening the waiting time and greatly improving efficiency.

**4000** »   
CYCLES OF CHARGING      **75% LI-ION**

Under normal charging and discharging conditions, the lithium battery of Hangcha products has a capacity retention rate of more than 75% and a life span of up to 10 years after 4000 cycles of charging and discharging.

HIGH-VOLTAGE

**247kWh**

Battery capacity

THE *Plus*  
FOR YOUR  
BUSINESS



# REVOLUTIONARY PERFORMANCE.



## Driving System

A maintenance-free high-pressure water-cooled permanent magnet synchronous drive motor is used, which has high power, high efficiency, complete protection functions, motor, greatly improved reliability and service life, and reduced maintenance costs. The two-stage decelerating heavy-duty drive axle of an internationally renowned brand (Kessler), with a multi-disc wet driving brake and a motor to aid the braking, is safe and reliable. The system is fully enclosed and maintenance-free and is applicable to heavy-duty operating conditions.



## Electrical System

An advanced permanent magnet synchronous motor drive controller and vehicle controller are used to realize electronic control of the driving, lifting, braking and steering actions of the forklift. Stable and accurate control, superior speed regulation performance and the functions of regenerative braking, reverse braking and protection for preventing sliding down a ramp, etc., enable safer and more effective and comfortable operations. With large LCD screens to display remaining battery life and have the functions of timer, fault self-diagnosis, mode selection, etc., the human-machine interface-equipped instruments of leading international brands can accurately display information in harsh environments. An energy-saving and environmentally friendly LED lighting system is used.



## Hydraulic system

An electric proportional multiway valve of an internationally renowned brand, a silent gear pump, a pilot control joystick and a high-pressure water-cooled permanent magnet synchronous oil pump motor are used. The load sensing hydraulic system can reduce the continuous load of the oil pump motor. The remote electrically-controlled operating mode is simple, convenient and dexterous. Multiple hydraulic test points are added to simplify repair and maintenance work. [The hydraulic system power source uses a Casappa gear pump, a Danfoss PVG multiway valve and a Danfoss hydraulic steering gear]



## Braking System

The hydraulic power brake valve with dual pressure curves enables a softer foot feel. A multi-disc wet driving brake acting with a spring, a hydraulically released caliper-type parking brake system and a forced cooling oil circuit are provided, safe and reliable.



## Mast System

The widened duplex mast enables higher torsion resistance of the mast and a broader view and double speed limiting valve oil circuits enable higher safety. Hydraulic pitch adjustment and side shift are provided for the standard configuration.



## Steering system

With a load sensing function, the single steering axle with horizontally-placed double acting cylinders enables fully hydraulic prioritized steering to be carried out easily.

## Cab



- Fully enclosed integral cab The cab adopts connection with four-point shock-absorbing rubber to reduce vibration, and is equipped with electric and manual tipping mechanisms to facilitate routine maintenance.
- The large cab floor and ample overhead and leg space enable the driver to enter and leave the cab easily at any time.
- The fully enclosed cab is heatproof, dust-proof and waterproof.
- There are sunshades in the cab and a filter at the fresh air inlet, and the internal circulation fan is adjustable.
- The air conditioner and heater can keep the cab at a comfortable temperature.
- The seat can be adjusted forwards and backwards and the angle of the backrest is adjustable, to make the driver more comfortable.
- The front, rear and top windshields are equipped with cleaners and wipers and the front and rear windshields are equipped with defrosters.
- All glass is safety glass.



# ENJOY YOUR WORK.

## Performance with a panorama view

The wide-view mast with optimized design is unlikely to obstruct the operator's line of sight. The enlarged opening size of the fork carriage enables a wider view, a large operation space, and excellent ergonomic design.



## New fully-suspended cab

The new fully-suspended cab with panoramic view enables a clearer view. Performance of the air conditioner is improved to enable uniform conditioned air blowing from the air outlet and a strong cooling effect. The waterproof, dust-proof, heatproof, soundproof, noise-reducing sealing design improves driving comfort. The molded interior parts enable a more comfortable feel. The integral frame is constituted by profiled steel pipes. The structural parts have higher strength.



The multifunctional color-screen instruments are designed to have graphical interfaces and display data clearly. The interfaces can be switched to be shown in Chinese and English.

The compact integral joystick enables accurate remote control. The optimized hydraulic braking curve enables smooth easy-to-control braking. The suspended seat and ergonomically-movable multidirectional adjustable console enable comfortable control.

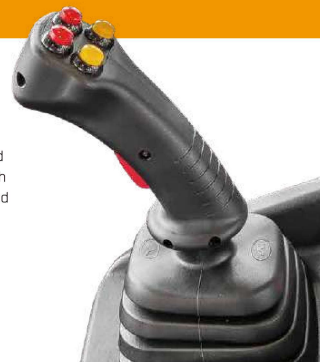

## Excellent heat dissipation Performance

For the first time, a water cooling system is used for controlling the motor, electric control and battery and achieving a good heat dissipation effect, so that the forklift can absolutely carry out long-time and high-intensity operations as internal combustion forklifts.



## Dependable powertrain

The vehicle adopts a whole machine controller to redeploy the traction integrated controller (PDU+DC/DC+MCU) to form an intelligent driving system, being light-weighted, efficient and independent.

The vehicle's high-voltage platform, standard 540.96V or optional 608.58V, equipped with a heavy truck water-cooled standard box features better heat dissipation, longer endurance mileage and more durable battery.

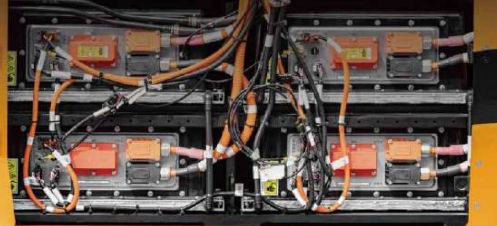

# ADVANCEMENT

Both the drive and operating systems are vehicle-grade permanent magnet synchronization systems. The driving speed, upslope degree and acceleration performance rival that of internal combustion vehicles, and the environmental performance is better than that of internal combustion vehicles.

	High Voltage Lithium Electric Forklift	Change to Diesel Forklift
Travel speed, laden/unladen	25km/h	27-31km/h
Lift speed, laden/unladen	340/360mm/s	350/380mm/s
Max. gradeability, S2+5min, laden/unladen	25%	25%







# SAFETY AND MAINTAINABILITY

Some key structural parts have been verified highly reliable by the market for many years while being used by internal combustion forklifts.



## Reliable

The cover of the vehicle is designed to be sealed to the water resistance level of IPX4. All the motor, electronic controls and high-voltage components reach the dust and water resistance level of IP67, a high protection level adequate to withstand harsh operating environments and ensure safety and reliability.



## MSD maintenance switch

The electrical system is equipped with high-voltage interlocks, insulation detection, and vehicle-grade safety means. The MSD (Manual Service Disconnect) maintenance switch enables one-click power-down and safer maintenance.

## Dual charging

TEVC-240KW-WX, Three-Phase  
460V/60Hz-Three-phase Five-wire



The wide-opened hood better facilitate repair and maintenance of electrical components.



The over-turnable cab and electric tipping cylinder make tipping easier and more labor-saving.

## Optional battery list

Capacity/voltage	608.58V	540.96V
604Ah	○	—
456Ah	—	●

Note: ● Standard battery capacity, ○ Optional battery capacity, — Null

## XH Series High-voltage Lithium Battery Forklift Specification

Distinguishing mark	HANGCHA GROUP CO.,LTD.				
	1.1	Manufacturer			
1.2	Manufacturer's type designation	CPD200-XHL2G	CPD250-XHL2G		
1.3	Drive: electric (battery or mains), diesel, petrol, fuel gas	Electric	Electric		
1.4	Operator type: hand, pedestrian, standing, seated, order-picker	Seated	Seated		
1.5	Rated capacity/rated load	0 [kg]	20000		
1.6	Load centre distance	c [mm]	1200		
1.8	Load distance, centre of drive axle to fork	x [mm]	1100		
1.9	Wheelbase	y [mm]	4250		
Weight	2.1	Service Weight	kg	35100	
	2.2	Axle loading, laden front/rear	kg	49700/5400	
2.3	Axle loading, unladen front/rear	kg	18460/16640		
Tyres, chassis	3.1	Tyres: solid rubber, superelastic, pneumatic, polyurethane	Pneumatic	Pneumatic	
	3.2	Tyre size, front	14.00-24-28PR	14.00-24-28PR	
3.3	Tyre size, rear	14.00-24-28PR	14.00-24-28PR		
3.5	Wheels, number front / rear (x = driven wheels)		4x/2	4x/2	
3.6	Tread, front	b10 [mm]	2200	2200	
3.7	Tread, rear	b11 [mm]	2300	2300	
Dimensions	4.1	Tilt of mast/fork carriage forward/backward	$\alpha/\beta$ [°]	6/10	6/10
	4.2	Height, mast lowered	h1 [mm]	3900	3900
	4.3	Free lift	h2 [mm]	110	110
	4.4	Lift	h3 [mm]	4000	4000
	4.5	Height, mast extended	h4 [mm]	5890	5890
	4.7	Height of overhead guard (cabin)	h6 [mm]	3580	3580
	4.12	Coupling height	h10 [mm]	680	680
	4.19	Overall length	l1 [mm]	8640	8708
	4.20	Length to face of forks	l2 [mm]	6200	6268
	4.21	Overall width	b1 [mm]	3050	3050
	4.22	Fork dimensions	s/e/l [mm]	110/250/2440	110/250/2440
	4.24	Fork-carriage width	b3 [mm]	3000	3000
	4.25	Distance between fork-arms	b5 [mm]	900/2600	900/2600
4.31	Ground clearance, laden, below mast	m1 [mm]	280	280	
4.32	Ground clearance, centre of wheelbase	m2 [mm]	345	345	
4.34.1	Aisle width for pallets 1000 x 1200 crossways	Ast [mm]	8100	8100	
4.34.2	Aisle width for pallets 800 x 1200 lengthways	Ast [mm]	8300	8300	
4.35	Turning radius	Wt [mm]	5800	5800	
4.38	Internal turning radius	b13 [mm]	545	545	
Performance data	5.1	Travel speed, laden/unladen	km/h	25/25	25/25
	5.2	Lift speed, laden/unladen	m/s	0.34/0.36	0.34/0.36
	5.3	Lowering speed, laden/unladen	m/s	0.40/0.35	0.40/0.35
	5.6	Max. Drawbar pull, laden/unladen	N	160000	160000
	5.8	Max. gradeability, laden/unladen	%	25/25	25/25
5.10	Service brake		Wet disc brake system(WDB)	Wet disc brake system(WDB)	
	Parking brake		Spring Applied, Hydraulic release multidisc brake(SAHR)		
Electric drivetrain	6.1	Drive motor rating S9 60 min Rated /Peak	kW	193/334	193/334
	6.2	Lift motor rating at S9 15% Rated /Peak	kW	2 x 50/100	2 x 50/100
	6.4	Battery Capacity	kWh/AH	247/456	247/456
		Nominal Voltage	V	541	541
	6.5	Battery weight	kg	3310	3310
	Battery dimensions	l/b/h [mm]	1900/1410/886	1900/1410/886	
	Max. battery weight	kg	2200	2200	
	Min. battery weight	kg	3200	3200	
Additional data	10.3	Hydraulic Tank - capacity (drain & refill)	liter	500	500
	10.7	Sound pressure level at the driver's seat	dB [A]	71	71
	10.8	Towing coupling, type DIN 15170		$\phi$ 50 Pin	$\phi$ 50 Pin
	Hydraulic system working pressure	MPa	26	26	

## 20-25t Mast Specification:(Pneumatic)

Type	Model	Max. fork height	Overall height		Tilt range	Capacity	
			Lowered	Extended		Load Capacity at 1200mm	
		mm	mm	mm	(°)	20t	25t
						kg	kg
2-stage wide view mast	GXR250M330	3300	3550	5190	6/10	20000	25000
	GXR250M360	3600	3700	5490	6/10	20000	25000
	GXR250M400	4000	3900	5890	6/10	20000	25000
	GXR250M430	4300	4050	6190	6/10	20000	25000
	GXR250M450	4500	4150	6380	6/10	20000	25000
	GXR250M480	4800	4300	6690	6/10	20000	25000
	GXR250M500	5000	4450	6940	6/10	20000	25000
	GXR250M550	5500	4700	7440	3/6	18500	23500
	GXR250M600	8000	5000	7990	3/6	17000	22000
	GXR250M650	6500	5250	8490	3/6	15000	20000
GXR250M700	7000	5550	9040	3/6	13000	18000	

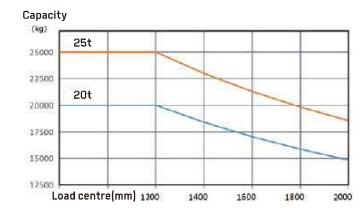
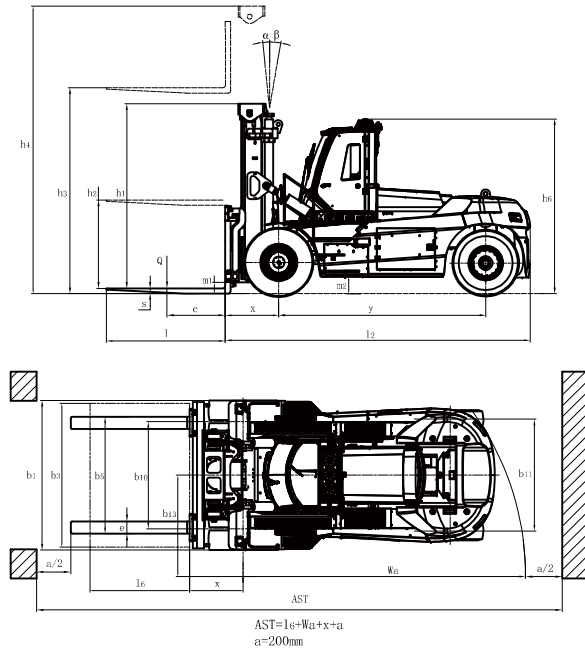

## Features

Transmission	Standard	Options
Pneumatic tyre	●	
Solid tyre		○
Steering system		
Fully hydraulic power steering	●	
Centralized lubrication system (machine)		○
Truck		
Tow pin	●	
Rear-view mirror on right & left mudguards	●	
Electrostatic discharge chain		○
Operating system		
Integrated joystick	●	
Adjustable steering column	●	
Adjustable armrest	●	
Hydraulic system		
Four-way hydraulic valve	●	
Operation proportion control	●	
Cab		
Cabin	●	
Climate control system (air-conditioning and heater)	●	
Manual tilting cabin	●	
Electric tilting cabin	●	
Radio	●	
Sunshade	●	
USB charging interface	●	
Clothes hanger hook	●	
Reading light	●	
Fan	●	
1 x 24V power supply		○
1 x 12V power supply		○
License plate frame		○
Lifting components		
Duplex mast	●	
Standard lifting height	●	
Standard fork	●	
Hydraulic Fork Positioning	●	
Built in Sideshift	●	
Optional lifting height		○
Other fork specifications		○
Fork hook on type		○
Independently-adjustable fork		○
Other		
Standard color	●	
Vehicle toolkit	●	
User defined colour		○
Fire extinguisher (2kg /4kg)		○

Electrical System	Standard	Options
Operator Presense System (OPS) with buzzer	●	
LCD display screen	●	
Main power switch	●	
Emergency power off switch	●	
Maintenance-free 24V lead acid battery	●	
Reverse buzzer	●	
High decible horn	●	
LED lights (entire vehicle)	●	
2 x Working light on front mudguard	●	
2 x Front working light on top of cabin	●	
2 x Rear working light on top of cabin	●	
2 x Working light on both sides of mast	●	
Reverse sensor	●	
Rearview camera system	●	
Flashing warning light (non rotating) with control switch	●	
On-board diagnostics system	●	
Water cooling system for lithium battery	●	
Automatic fire suppression system for lithium battery pack	●	
Automatic fire suppression system		○
Manual Service Disconnect (MSD) switch	●	
High voltage interlock	●	
Insulation protection	●	
Power-on self-test	●	
Energy recovery (braking regeneration)	●	
Vehicle Control Unit (VCU)	●	
Dual charging ports	●	
Hour meter	●	
Battery charge indicator	●	
Low hydraulic pressure alarm indicator	●	
Hydraulic oil filter warning indicator	●	
Drive mode indicator	●	
Parking brake indicator	●	
Service indicator		○
Rearview camera system with memory		○
Front & rearview camera system		○
Front & rearview camera system with memory		○
4 directions camera system with single display		○
4 directions camera recording system with single display		○
In cabin CCTV		○
Rear blue safety light		○
Front and rear blue safety light		○
Three sided blue danger zone light		○
Overspeed alarm		○
Speed limitation		○
Voice reverse alarm		○
Two-way radio		○
Weight indicator in display		○
Tyre pressure monitoring		○
Turning deceleration		○