

APPROXIMATE DATA - TECNICHE AENDERUNGEN VORBEHALTEN
 DONNES INDICATIVES - DATI INDICATIVI

TOLLERANZA
 TOLERANCE
 TOLERANCA
 TOLERANZ
 + 0%
 - 5%

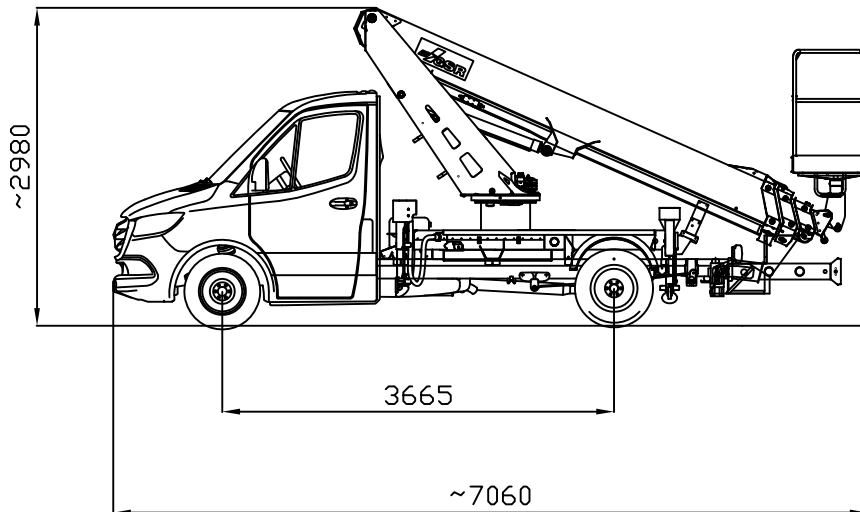

MAX SAFE WORKING LOAD	 250 KG
MAX NENNTRAGFAHIGKEIT IM KORBE	
MAX CHARGE NOMINALE DANS LE PANIER	
MAX PORTATA NOMINALE IN NAVICELLA	
ALUMINIUM BASKET	

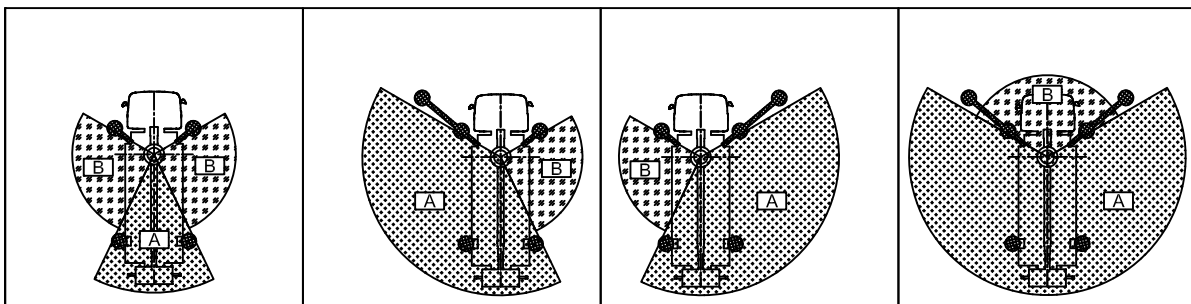

DENOMINAZIONE
B200T4 Comfort
 MERCEDES 311CDI - 3.5 t

DATE 15-06-2020
 CODE PRP1636

Aggiornamenti - Modifiche:

C	F
B	E
A	D